

Oral Session
November 14

”Hinode”; A New Solar Observatory in Space
– Current Status –

S. Tsuneta¹

¹*National Astronomical Observatory of Japan*
saku.tsuneta@nao.ac.jp

Hinode (SOLAR-B) was successfully launched on September 24 2006. It carries three telescopes (solar optical telescope, X-ray telescope, and EUV imaging spectrometer) to observe the generation and transport of magnetic fields, and to simultaneously observe the dissipation part of the solar magnetic fields. Solar optical telescope has unprecedented spatial resolution with high polarimetric accuracy to observe the Sun. First light operation will be presented in the talk.

First Light of Solar Optical Telescope (SOT) on *HINODE*

Y. Katsukawa

National Astronomical Observatory of Japan, NINS, Mitaka, Tokyo, JAPAN

yukio.katsukawa@nao.ac.jp

HINODE (SOLAR-B) spacecraft was successfully launched on September 23, 2006 from Uchinoura Space Center (USC). The Solar Optical Telescope (SOT) aboard *HINODE*, which is the largest telescope with 50 cm aperture, has just started its observation from the end of October after the spacecraft commissioning phase for one month. A major advantage of the telescope is that it provides high resolutional images of solar surface visible by optical wavelength with uniform image quality without interruption by earth atmospheric effects nor day/night. It also has powerful performance for diagnostic of the magnetic fields on the solar surface with a spectro-polarimeter and a narrow-band filter imager. It is expected to become possible to continuously track evolution and motion of fine magnetic elements in the photosphere by SOT, and its eventual dissipation in the corona by simultaneous observations with X-Ray Telescope (XRT) and EUV Imaging Spectrometer (EIS). First light result obtained by SOT is presented in the talk.

***Hinode* X-ray Telescope and EUV Imaging Spectrometer**

H. Hara

National Astronomical Observatory of Japan, Mitaka, Tokyo, JAPAN

hirohisa.hara@nao.ac.jp

Hinode spacecraft, which was launched as Solar-B on 2006 Sep 23, carries Solar Optical Telescope (SOT), X-ray Telescope (XRT), and EUV Imaging Spectrometer (EIS). This paper introduces the performance and scientific targets of XRT and EIS.

XRT is a grazing-incidence X-ray telescope having a spatial resolution of 2 arcsec with 1 arcsec pixel sampling. Its field of view covers the whole sun when the spacecraft points to the center of the sun. In addition to the high spatial resolution the automatic exposure control according to the change of target brightness, automatic bright region tracking, on-board flare detection, and a high-cadence pre-flare observation are possible. The telescope has sensitivity for 1–30 MK and the sensitivity for 1–2 MK plasmas is largely improved from that of the *Yohkoh* soft X-ray telescope. Dynamic events and plasma heating happening in the solar corona will be investigated in the high-resolution imaging observations.

EIS is a normal-incidence EUV imaging spectrometer of 2 arcsec spatial resolution and 47–58 mÅ spectral resolution. It observes two wavelength ranges of 170–210 and 250–290 Å, in which there are emission lines that are sensitive to plasmas of $10^{4.7} - 10^{7.3}$ K. In addition to the line spectroscopy with slits of 1 and 2 arcsec widths, imaging observations with slots of 40 and 266 arcsec widths are possible. Plasma motions and plasma heating can be studied from the line-profile spectroscopy and line-ratio technique. One of the objectives is to observe the plasma flows around the magnetic reconnection site.

X-ray images from XRT and EUV spectra from EIS that are to be obtained in the post-launch operation may be shown as a quick report.

Magnetosphere-Ionosphere Coupling: A Modeler's Perspective

F. R. Toffoletto¹, R. A. Wolf¹, S. Sazykin¹ and R. W. Spiro¹

¹ *Physics and Astronomy Department, Rice University, Houston, TX, USA*

toffo@rice.edu

Magnetosphere-ionosphere coupling plays an important role in determining the structure and dynamics of both the magnetosphere and ionosphere. In this review we describe the many physical processes that couple the two regions, how these processes have been incorporated into large-scale models of the coupled system, and what we can learn about the global behavior of the magnetosphere-ionosphere system from these models. Specific examples are drawn from our experience using the Rice Convection Model (RCM) to model a variety of physical situations in the coupled system, as well as our on-going effort to self-consistently couple the RCM to both global MHD models of the magnetosphere and increasingly refined and sophisticated ionosphere/thermosphere models.

Development of the NICT real-time thermosphere-ionosphere simulator

H. Shinagawa^{1,2,5}, H. Shimazu^{1,2,5}, N. Terada^{1,5}, M. Nakamura^{1,5}, S. Fujita^{4,5}, T. Tanaka^{2,3,5},
and T. Obara^{1,5}

¹ *National Institute of Information and Communications Technology, Koganei, Tokyo, JAPAN,*

² *Space Environment Research Center, Kyushu University, Fukuoka, JAPAN,*

³ *Department of Earth and Planetary Sciences, Kyushu University, Fukuoka, JAPAN,*

⁴ *Meteorological College, Kashiwa, Chiba, JAPAN,*

⁵ *CREST, JST*

sinagawa@nict.go.jp

During magnetic storms, a large amount of energy is deposited into the ionosphere-thermosphere system. The ionosphere and the thermosphere are significantly disturbed by the energy inputs from the magnetosphere. Ionospheric disturbances could affect various communication and broadcasting systems as well as GPS positioning systems. The neutral density in the thermosphere enhanced by Joule and particle heating could occasionally alter orbits of low-altitude satellites by air drag force. In order to predict various hazards associated with the upper atmospheric disturbances, it is important to develop a real-time numerical model of the ionosphere and thermosphere.

Recently, a real-time global magnetohydrodynamic (MHD) model of the solar wind interaction with the earth's magnetosphere has been developed at the National Institute of Information and Communications Technology (NICT) in collaboration with Kyushu University and the Meteorological College. The model is now operated at the space weather forecast center of NICT to understand present state of the magnetospheric environment and to predict near-future geospace disturbances. The structure of the magnetosphere obtained by the real-time magnetospheric model is presented at the Web site (<http://www.nict.go.jp/y/y223/simulation/realtime/>). The model is also able to give ionospheric parameters such as electric conductivities and the electric potential in the high-latitude region. We have started to develop a real-time ionosphere-thermosphere simulation model using the ionospheric parameters given by the real-time magnetospheric MHD model.

We will describe the current status and future prospects of our real-time ionosphere-thermosphere model. Preliminary results will be presented and compared with observations.

GCM simulations of the thermosphere/ionosphere

H. Fujiwara¹ and Y. Miyoshi²

¹ *Department of Geophysics, Tohoku University, Sendai, JAPAN,*

² *Department of Earth and Planetary Science, Kyushu University, Fukuoka, JAPAN*

fujiwara@pat.geophys.tohoku.ac.jp

The solar radiation, solar wind, magnetosphere, ionosphere, thermosphere, and mesosphere can influence the space-borne and ground-based technological systems which are essential for human life in the 21st century. For example, thermospheric/ionospheric disturbances are capable of perturbing the orbital characteristics of low-earth-orbiting satellites and having influences on radio communication, e.g., navigation systems using Global Positioning System. In order to understand thermospheric/ionospheric disturbances in association with geomagnetic storms/substorms, modeling efforts have been made by some research groups. For example, the first thermospheric general circulation model (GCM) was developed by the group of University College London (UCL), UK. GCMs originated from the UCL model have been now updated to be coupling with the mesosphere, ionosphere, and plasmasphere. Another sophisticated model, which was called Thermospheric GCM (TGCM), was developed by National Center for Atmospheric Research (NCAR), USA. TGCM has been updated to Thermosphere-Ionosphere GCM (TIGCM), Thermosphere- Ionosphere and Electrodynamics GCM (TIEGCM), and Thermosphere, Ionosphere, Mesosphere Electrodynamics GCM (TIME-GCM). Now GCMs for the thermosphere/ionosphere include several regions and simulate coupling effects between them. In addition to the above GCMs, Miyoshi and Fujiwara (2003) developed a new GCM which covers all the atmospheric regions, the troposphere, stratosphere, mesosphere, and thermosphere, as an extension of the middle atmosphere GCM developed at Kyushu University. This GCM is a quite powerful tool for investigating the coupling between the upper and lower atmospheres: e.g., tidal variations from the troposphere to the thermosphere. Furthermore, this GCM successfully simulates the generation and propagation of the large-scale traveling atmospheric disturbances (LS-TADs) in the thermosphere during both geomagnetically disturbed and quiet periods. Figure 1 shows an example of the thermospheric temperature and horizontal wind simulated at about 300 km altitude during a geomagnetically quiet period (solar minimum and November conditions are assumed). In addition to the day-night difference of temperature and wind distributions, localized temperature structures are also seen in Figure 1. In this paper, we overview the previous modeling studies of the thermosphere/ionosphere and simulations of thermospheric/ionospheric disturbances. New features of the TADs clarified by our GCM simulations are also shown here.

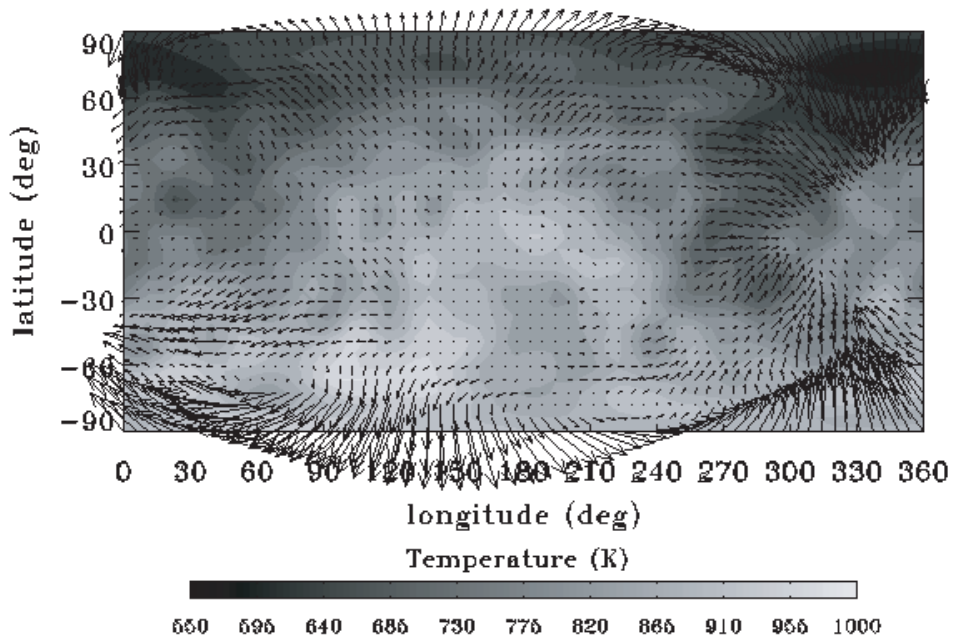

Figure 1: An example of the thermospheric temperature and horizontal wind simulated at about 300 km altitude.

Emergence and eruptions of magnetic flux in the solar atmosphere

V. Archontis

School of Mathematics and Statistics, University of St. Andrews, North Haugh, UK

vasilis@mcs.st-and.ac.uk

Numerical simulations show that the emergence of magnetized plasma from the solar interior in the solar atmosphere is followed by a host of dramatic phenomena. The rising magnetized field quickly establishes links to other flux systems it encounters in the corona, possibly through magnetic reconnection. Ejection of plasmoid-like structures and emission of hot and fast plasma jets is a natural by-product of resistive instabilities and reconnection. A summary of the history of the subject will be given together with a brief overview of relevant observations. Recent 2D and 3D experiments of the interaction of emerging fields with pre-existing coronal fields will be discussed. The importance of the information that the Hinode mission will provide in association with the flux emergence in the outer atmosphere of the Sun will also be discussed.

Observational Evidences of Emerging Twisted Magnetic Flux Ropes in Strong Flare Regions

H. Kurokawa¹ and T. T. Ishii¹

¹ *Kwasan and Hida Observatories, Graduate School of Science, Kyoto University*
kurokawa@kwasan.kyoto-u.ac.jp

The forecast of strong flare occurrence is indispensable to protect human activities in the space. The flare energy, which is stored in the twisted magnetic field, is supplied to the corona through the photosphere from the convection zone. For this reason, observations of evolutionary changes in the magnetic field configuration of flare-productive regions are fundamentally important for the flare energy build-up study and the forecast of strong flares. Until now several works made detailed studies of magnetic shear developments in flare-productive sunspot regions and suggested that the emergence of a twisted magnetic flux rope, which is originally formed in the convection zone, must be the source of the strong magnetic shear development in a sunspot region to produce a strong flare activity (Kurokawa 1987, Tanaka 1991, Ishii et al. 1998, Kurokawa 2002).

In this paper we present our recent studies of 11 super active regions which produced more than three X-class flares during the 23 sunspot cycle. We define three typical emerging features of twisted flux ropes and show that most of the super active regions observed during the 23 sunspot cycle are classified into one of the three types of emerging twisted flux ropes.

Coronal Mass Ejections and Adverse Space Weather

N. Gopalswamy¹, S. Yashiro², S. Akiyama², H. Xie², and R. A. Howard³

¹ *NASA Goddard Space Flight Center, Greenbelt, Maryland, USA,*

² *The Catholic University of America, Washington, DC, USA,*

³ *The Catholic University of America, Washington, DC, USA*

gopals@ssedmail.gsfc.nasa.gov

The Solar and Heliospheric Observatory (SOHO) mission has observed more than 10,000 coronal mass ejections (CMEs) since 1996. The average speed (~ 480 km/s) of the CMEs is slightly above the slow solar wind speed and the angular width is ~ 45 degrees. These numbers are consistent with pre-SOHO observations. Recent statistical analysis shows that about 10% of all CMEs have such high speeds. The cumulative distribution of CME speeds indicates that the number of CMEs with speeds exceeding 3000 km/s is precipitously small. Simultaneous observations of type II radio bursts, solar energetic particles and geomagnetic storms have shown that these phenomena are closely related to fast and wide CMEs. Over the whole solar cycle 23, only about 1000 such CMEs have been observed. These CMEs constitute a special population because they have significant consequence in the heliosphere. Understanding the origin and propagation of these CMEs is therefore very important from a practical point of view. Current simulation works on CMEs generally deal with slow CMEs, although some recent works have started focusing on fast CMEs. This paper reviews the observational properties of fast CMEs and their consequences in the heliosphere and in the near-Earth Space Environment.

Tracing CMEs from the corona to 1 AU in radio emission

S. Pohjolainen¹, L. van Driel-Gesztelyi^{2,3,4}, L. Culhane², P.K. Manoharan⁵, and H.A. Elliott⁶

¹ *Tuorla Observatory/Department of Physics, University of Turku, Turku, FINLAND*

² *Mullard Space Science Laboratory, University College London, Dorking, UK*

³ *Konkoly Observatory of the Hungarian Academy of Sciences, Budapest, HUNGARY*

⁴ *Observatoire de Paris, LESIA, Meudon, FRANCE*

⁵ *Radio Astronomy Centre, Tata Institute of Fundamental Research, Ooty, INDIA*

⁶ *Southwest Research Institute, San Antonio, Texas, USA*

silpoh@utu.fi

Propagating shocks in the corona and interplanetary space can excite plasma waves that finally convert into radio waves. Frequency-drifting solar radio bursts observed in dynamic spectra can be used to trace the burst drivers. With the help of atmospheric density models we can calculate shock speeds from the frequency drifts observed in metric and decametric radio data. Furthermore, radio scintillation images of the inner heliosphere can be used to locate plasma density irregularities in the solar wind, formed by the propagating CMEs. We can then compare the speeds obtained from radio observations with the CME velocities, as observed in the plane-of-the-sky white light observations and calculated with cone models. The CME heights in white light can also be used as constraints for the radio source heights. Finally, these results can be compared with the arrival times of the interplanetary shocks near Earth. We discuss the different methods for CME speed determination and present results on one particular event, the fast halo-type CME on 7 November 2004.

Oral Session
November 15

Nonlinear force-free field modeling of the solar coronal magnetic field

T. Wiegelmann¹

¹ *MPI for Solar System Research, 37191 Katlenburg-Lindau, Germany*

wiegelmann@mps.mpg.de

The coronal magnetic field is an important quantity because the magnetic field dominates the structure of the solar corona. Unfortunately direct measurements of coronal magnetic fields are usually not available. The photospheric magnetic field is measured routinely with vector magnetographs. These photospheric measurements are extrapolated into the solar corona. The extrapolated coronal magnetic field depends on assumptions regarding the coronal plasma, e.g. force-freeness. Force-free means that all non-magnetic forces, e.g. pressure gradients and gravity are neglected. While this assumption is well justified in the solar corona due to the low plasma beta, the magnetic field is not force-free in the photosphere. Ambiguities and noise in the transversal photospheric magnetic field measurements are an additional complication for reliable coronal magnetic field extrapolations. To deal with this problems we first preprocess the measured photospheric data. The preprocessing procedure provides us suitable boundary conditions for a nonlinear force-free extrapolation. We solve the force-free and solenoidal condition with an optimization code. A generalization of the nonlinear force-free optimization principle allows the inclusion of non magnetic forces like pressure gradients and gravity.

Nonlinear Force-Free Field Modeling of Solar Coronal Magnetic Fields

Y. Yan¹

¹ *National Astronomical Observatories, Chinese Academy of Sciences, Beijing 100012, China*
yyh@bao.ac.cn

Solar magnetic fields provide excess energy in the solar energetic processes such as flares, CMEs, etc. This excess energy must come from the non-potential field as demonstrated by observed vector magnetograms. At present the reliable measurements of solar magnetic fields are still confined to lower levels like the photosphere and the coronal magnetic field can be reconstructed using a certain model with the observed data as boundary condition. The successful launch of Solar-B and other facilities will provide more qualified vector magnetograms and better understanding of solar coronal magnetic fields should be achieved. Here we introduce the boundary integral formulation of nonlinear force-free fields in the solar corona that applies vector magnetograms as boundary condition without assuming arbitrarily lateral boundary conditions.

Non-linear force-free magnetic field extrapolation scheme based on the direct boundary integral formulation

Han He and Huaning Wang

National Astronomical Observatories, Chinese Academy of Sciences, Beijing, China

hehan@bao.ac.cn

The boundary integral equation (BIE) is first proposed by Yan & Sakurai (1997, 2000), which is used to extrapolate the force-free magnetic field in the solar atmosphere. Recently, Yan & Li (2006) improved the BIE and proposed the new Direct Boundary Integral Equation (DBIE) formulation, which represents the force-free magnetic field in a semi-space by direct integration of the magnetic field on the boundary plane surface. The DBIE in principles can save much computing time as compared with the original BIE formulation. In this talk, we present our practical calculation scheme for the non-linear force-free magnetic field extrapolation above solar active regions based on this new method, and give a perspective on the application of the method to the global extrapolation above the spherical surface of the Sun.

Simulations of the Sun-Earth System: Modeling the Halloween Events with SWMF

W. Manchester, T. Gombosi, G. Toth, I. Sokolov, D. De Zeeuw, and A. Ridley

Center for Space Environment Modeling, University of Michigan, USA

chipm@umich.edu

The Space Weather Modeling Framework (SWMF) aims at providing a flexible framework for physics based space weather simulations. The SWMF combines numerical models of the Solar Corona, which includes the Eruptive Event Generator, the Inner Heliosphere, Solar Energetic Particles, Global Magnetosphere, Inner Magnetosphere, Radiation Belt, Ionosphere Electrodynamics and Upper Atmosphere into a parallel, high performance model. All the components can be replaced with alternatives, and one can use only a subset of the components. The SWMF enables us to do simulations that were not possible with the individual components. We highlight some numerical simulations obtained with the SWMF in modeling some of the most violent solar outbursts in recent history, the so called Halloween Events of 2003. Very fast coronal mass ejections associated with the Halloween Events hit the magnetosphere and generated very large magnetic storms. Our simulation of these events goes from the Sun to the upper atmosphere using all SWMF components, which provides an opportunity to test both the robustness and accuracy of the SWMF. A realistic method of CME initiation based on shear flows driven by the Lorentz force will also be discussed.

Numerical Modeling of May 1998 Interplanetary CME Events

D. Odstrcil^{1,5}, C. N. Arge², Y. Liu³, G. Michalek^{4,6}, V. J. Pizzo⁵, P. Riley⁷, H. Xie⁶, X. P. Zhao³

¹ *University of Colorado, Boulder, CO, USA,*

² *AFRL, Hanscom AFB, MA, USA,*

³ *Stanford University, Stanford, CA, USA,*

⁴ *Astronomical Observatory, Krakow, Poland,*

⁵ *NOAA/SEC, Boulder, CO, USA,*

⁶ *NASA/GSFC, Greenbelt, MA, USA,*

⁷ *SAIC, San Diego, CA, USA*

dusan.odstrcil@noaa.gov

We simulate the May 1998 interplanetary coronal mass ejection (ICME) events with a numerical 3-D magnetohydrodynamic (MHD) model, in which the background solar wind is determined from the SAIC and WSA coronal models, and the transient disturbance from various cone-models fittings of the white-light CME observations. The heliospheric simulations using cone models may provide a global context of transient disturbances within a co-rotating, structured solar wind and they can serve as an intermediate solution until more sophisticated CME models become available. ICMEs generate trailing rarefaction waves which expand with increasing time (distance) and disturbed solar wind can persist for about one day in the inner heliosphere. Since the ICME parameters depend on parameters of previous ICMEs, multiple-events scenario has to be simulated. Interplanetary magnetic field (IMF) lines are stretched up (under-wound) in rarefaction region and connectivity of the IMF lines between an interplanetary shock and geospace changes in time. Using different solar wind and cone models enables to trust the predicted parameters better, if different models make similar predictions and alert us to be more cautious when large differences are present.

MHD simulation of solar corona and solar wind and the sub-Alfvénic boundary treatments to utilize the measurement data.

Keiji Hayashi¹

¹ *W. W. Hansen Experimental Physics Laboratory, Stanford University, Stanford, California, USA*
keiji@quake.stanford.edu, khayashi@stanford.edu

The time-dependent two/three-dimensional MHD simulation of the global solar corona and solar wind can be good tools for understanding the dynamics of interplanetary space and heliosphere. Because it typically takes three or four days for the solar wind to travel from the Sun to the Earth, the MHD simulation using updated datasets can also be used to predict the solar wind parameters, for example, at the Earth for space weather. For these purposes, it is important and essential to use the measurement data of the solar magnetic field and the plasma to assign the period and situation to be simulated. Such data assimilation can be done by using these data as the boundary conditions of the simulation. In this paper, we will introduce two features of our simulation effort designed for better simulations of the global solar corona and solar wind.

One feature is that the boundary treatment in our MHD code is based on the concept of the projected normal characteristic method (Nakagawa, 1980 ; Wu et al., 1983 ; Han et al., 1988). A difficulty in the simulation of the solar corona is that we have to treat the sub-Alfvénic solar surface. The MHD variables on the sub-Alfvénic boundary surface must vary in accordance with the conditions both above and beneath the surface, however, we do not have enough information on the interior of the Sun. A simple method for the MHD simulation to deal with the boundary variables is the fixed boundary condition that assumes the incoming waves always cancel the outgoing waves. This assumption generates undesirable numerical oscillations near the surface and often results in unphysical solutions. The projected normal characteristic method has a lot of merits; it can determine the temporal variations of the boundary MHD variables that fully satisfy both the given boundary values (measurement data) and the basic MHD equations, and the numerical oscillation will be minimized. Employing the normal projected characteristic method, we have proposed one boundary constraint; the mass flux escaping through the coronal hole is limited so that the contrast of coronal plasma density and temperature between the coronal hole and streamer will be well produced and the density flux at the distant region well agree with the Ulysses measurement (Hayashi, 2005).

The other feature is that we also use the temperature map at the coronal base obtained from SOHO/EIT image data (Hayashi et al., 2006). Many simulation studies had used only the solar photospheric magnetic field data at, for example, the SOHO/MDI, Wilcox Solar Observatory (of Stanford) and Kitt Peak Observatory. Because the solar coronal structure is determined through the interaction between the plasma and magnetic field, the simulation additionally using the temperature map will reproduce the solar coronal structures more realistically. The differences between the simulation results with and without the temperature data appear in the shape of the coronal magnetic field, for example, the heights of the coronal streamer and the size of the coronal hole. It should be mentioned that it was necessary to extrapolate the magnetic field at the base of corona using the solar photospheric magnetic field data because the altitudes which the magnetic field data and temperature data represent are different. We simply used the potential field model, and this point should be improved.

The main part of the MHD code we developed is based on TVD and MUSCL strategy. The grids are constructed in the spherical coordinate system so that the measurement data can be correctly imported as the boundary values. The parallelism is achieved with OpenMP or MPI. The calculations for this simulation study were performed in part on the SGI/altix of the Columbia supercomputing system at NASA/ARC and the Fujitsu/Primepower HPC2005 at Nagoya University.

A positively conservative scheme for MHD in space plasma simulations

T. Miyoshi¹ and K. Kusano²

¹ Graduate School of Science, Hiroshima University, Higashi-hiroshima, Hiroshima, JAPAN,

² Earth Simulator Center, JAMSTEC, Yokohama, Kanagawa, JAPAN,

miyoshi@sci.hiroshima-u.ac.jp

In order to clarify the plasma dynamics in the whole Sun-Earth system, accurate and stable MHD simulations are indispensable. Since shocks and discontinuities are often generated and interacted with each other in space plasmas, shock capturing schemes for MHD have been developed intensively about last two decades. The shock capturing schemes are based on the conservative form of the basic equations, and therefore, the conservation laws at the discontinuities (i.e., the jump conditions) can be satisfied even in the discrete level. In particular, the linearized Riemann solver like the Roe scheme has been widely used as the standard shock capturing scheme for MHD due to its high accuracy and resolution though it takes much computational cost rather than classical schemes such as the Lax-Wendroff scheme.

It is known, however, that the linearized Riemann solver cannot necessarily preserve the positivity of the density and the pressure even in simple one-dimensional shock tube problem. Moreover, in the Earth's magnetosphere, because large numerical errors due to the background potential magnetic field affect the estimate of the magnetic energy density, it is more difficult to maintain the pressure positive. In addition, when the approximate Riemann solver is applied to multi-dimensions, a correction of the magnetic field to clean the numerical magnetic divergence may lead negative pressure.

Therefore, in this paper, a positively conservative scheme for MHD that is robust and suitable for space plasma simulations is discussed. In order to construct the positively conservative scheme, we take notice of (a) base approximate Riemann solver, (b) influence of the background potential magnetic field, (c) divergence cleaning method in multi-dimensions, in particular.

(a) base approximate Riemann solver:

We adopt the HLL-type approximate nonlinear Riemann solver. In the HLL-type solver, using the assumption that the normal velocity is constant in the Riemann fan at the cell interface, the approximate solution of the Riemann problem is obtained algebraically. The most sophisticated version in the hierarchy of the HLL-type Riemann solver for MHD is the HLLD ("D" stands for Discontinuities) solver that can exactly resolve isolated discontinuities formed in MHD. The positivity preserving property of the HLLD solver was proved analytically for one-dimensional ideal MHD. The HLLD solver is more robust and efficient than the linearized Riemann solver, whereas its resolution is almost as high as that. We can also construct the solvers of a lower hierarchy, so-called HLL, HLLC ("C" denotes Contact), HLLR ("R" denotes Rotational) solvers, from the HLLD solver. Since the intermediate physical states of the HLL, HLLC, HLLR solvers are calculated from the intermediate states of the HLLD solver, the positivity preserving property of these solvers is also assured.

(b) influence of the background potential magnetic field:

In the interaction of the solar wind and the Earth's intrinsic magnetic field, the deviation of the magnetic field from the intrinsic field is of the same order in the whole system although the intensity of the full magnetic field rapidly decreases with respect to the distance by several orders of magnitude. Therefore, to remove large numerical errors caused by the background potential magnetic field, the effect of the background field is analytically separated from the conservative variables. This approach succeeded in the linearized Riemann solver. We show here that this approach is also applicable to the HLL-type approximate nonlinear Riemann solver by assuming the potential field is constant in the Riemann fan at the cell interface.

(c) divergence cleaning method in multi-dimensions

Since straightforward multi-dimensional extension of the Riemann solver for MHD commonly leads to an inappropriate numerical solution that breaks the solenoidal condition of the magnetic field, various divergence cleaning methods for the multi-dimensional MHD solver have been proposed so far and critically compared with each other. Although those methods work well in some cases, the positivity of the pressure may not be preserved in low beta plasmas because the corrected magnetic energy density can become larger than the total energy density. Therefore, we propose that only the perpendicular component of the magnetic field on the cell interface, rather than the magnetic field vector in the cell, should be corrected. In particular, in this study, this concept is applied to the projection method, which is one of the most effective divergence cleaning method for the multi-dimensional MHD solver. Numerical tests show that the present method gives a solution quite similar to the original projection method though all components of the magnetic field are not corrected.

The above results indicate that the positively conservative MHD scheme that is quite robust and suitable for the space weather modelling can be constructed by applying the present strategy.

Particle acceleration and transport in large SEP events

Gang Li^{1,2}, Olga Verkhoglyadova¹ and G. P. Zank²

¹ *IGPP, University of California, Riverside, CA 92521, USA*

² *Space Science Lab, University of California, Berkeley, CA 94720, USA*
ganli@ssl.berkeley.edu

Energetic particles in large SEP events are extremely detrimental to astronauts and instruments onboard spacecraft and are the No. 1 hazard in space weather studies. Particles in these events are believed to be accelerated at a shock driven by Coronal Mass Ejections (CMEs). When a CME-driven shock propagates out from the Sun, particles traverse back and forth at the shock front and gain energies through diffusive shock acceleration mechanism, aka 1st-order Fermi acceleration. When these high energy particles escape from the shock front, they propagate along interplanetary magnetic field lines and arrive at 1 AU before the shock, forming the SEP portion of the event. In contrast, particles of lower energies are trapped downstream of the shock, forming ESP portion of the event at the shock arrival.

To fully capture the acceleration, the transport and the trapping of energetic particles at the shock and in the interplanetary medium, we have developed a sophisticated model. The model tracks the propagation of the CME-driven shock using a 2D MHD (ZEUS) code and the acceleration of particles at the shock is followed numerically. The maximum energy at the shock is decided by particle diffusion coefficient, which is evaluated from the Alfvén wave intensity, calculated from the wave-particle resonance conditions. Finally, a Monte-Carlo code is developed to follow the transport of energetic particles when they escape from the shock into the interplanetary medium.

Time intensity profiles, particle spectra and Fe/O ratio can all be calculated from our model. And by using realistic solar wind parameters, our model will provide a good basis for interpreting the observations of specific SEP events.

SEP Properties and Magnetic Field Connection of the Source Region

N. V. Nitta¹

¹ *Lockheed Martin Solar and Astrophysics Lab., Palo Alto, CA 94304, USA*

nitta@lmsal.com

It is generally accepted that gradual SEP events are accelerated primarily by CME-driven shocks. However, variability of SEP properties suggests that particles accelerated in solar flares may also contribute to gradual SEP events. One of the key factors for determining the occurrence and basic properties of SEP events at high energies may be the magnetic field connection of the source region and surrounding areas to the Earth. For a number of SEP-productive active regions, we compare the properties of intense flares and energetic CMEs that originated from them over their disk passage with the peak fluxes and rise times of the associated >10 MeV and >50 MeV protons. We perform magnetic field extrapolation with the potential field source surface (PFSS) model to locate well-connected field lines with respect to the source region. Once evaluated against multiple criteria, the PFSS extrapolation would be a useful tool to characterize the magnetic field topology in and around the active region responsible for the intense flares and energetic CMEs. This study is expected to partially answer the question of whether flare-accelerated particles directly contribute to gradual SEP events.

Particle Acceleration by Shocks and the Whistler Critical Mach Number

M. Oka¹, T. Terasawa², N. Shimada³, H. Kojima⁴, Y. Kasaba³,
M. Fujimoto³, H. Matsumoto⁴, Y. Saito³, T. Mukai³

¹ *Kwasan Observatory, Kyoto University, Kyoto, JAPAN,*

² *Tokyo Institute of Technology, Tokyo, JAPAN,*

³ *Institute of Space and Astronautical Science, Japan Aerospace Exploration Agency, Kanagawa, JAPAN,*

⁴ *Research Institute for Sustainable Humanosphere, Kyoto University, Kyoto, JAPAN.*

moka@kwasan.kyoto-u.ac.jp

Particle acceleration by shocks is one of the most important process in space and in the context of space weather. To be able to quantitatively predict particle flux associated with solar eruptive events, we need to know the details of the dynamics of collisionless shocks. In this paper, we present recent progress of particle acceleration made by the GEOTAIL spacecraft at the Earth's bow shock and extend the results to particle acceleration by interplanetary shocks as well as shocks in the solar corona.

Our paper will be focused on the role of the so-called 'whistler critical Mach number M_{crit}^w '. Originally, it was introduced to indicate the critical Mach number below which whistler waves propagate upstream. However, we report that electron power-law spectral index changes dramatically across the whistler critical Mach number M_{crit}^w . We found that, at the shock transition layer of the bow shock, the spectral index Γ of electron energy spectra defined by $f(E) \propto E^{-\Gamma}$ distributed between 3.5 and 5.0 in the sub-critical regime, while these values were almost constant $\sim 3.0 - 3.5$ in the super-critical regime.

Recently, a theoretical work combined with PIC simulation has suggested that the whistler critical Mach number M_{crit}^w controls the non-stationary, cyclic behavior of shocks, so-called 'reformation' (Krasnoselskikh et al., 2002). By analyzing some of our sample shock crossing events in detail, we report observational evidence of shock reformation and discuss its condition of occurrence.

Then, knowing that M_{crit}^w plays a role in the dynamics of collisionless shocks, we will discuss possible relationship between M_{crit}^w and electron acceleration with a help of numerical simulation.

Electron acceleration via magnetic island coalescence

I. Shinohra, K. G. Tanaka, T. Yumura, M. Fujimoto¹

¹ Institute of Space and Astronautical Science/JAXA, Sagami-hara, Kanagawa, JAPAN
iku@stp.isas.jaxa.jp

Kinetic properties of quick magnetic reconnection triggering (QMRT) and subsequent magnetic island coalescence have been studied. We have carried out two- and three-dimensional full kinetic simulations of the Harris current sheet with large and long enough simulation runs for more than two islands coalescence. Due to the strong inductive electric field associated with the non-linear evolution of the lower-hybrid-drift instability and the magnetic island coalescence process observed in the non-linear stage of the collisionless tearing mode, electrons are significantly accelerated at around the neutral sheet and the subsequent X-line. The accelerated meandering electrons generated in the non-linear evolution of the lower-hybrid-drift instability are resulted in QMRT, and QMRT leads to fast magnetic island coalescence. As a whole, the reconnection triggering and its transition to the large-scale structure work as an effective electron accelerator. In this presentation, we will show the results of the detailed analysis on the acceleration process and will discuss the efficiency of the electron acceleration.

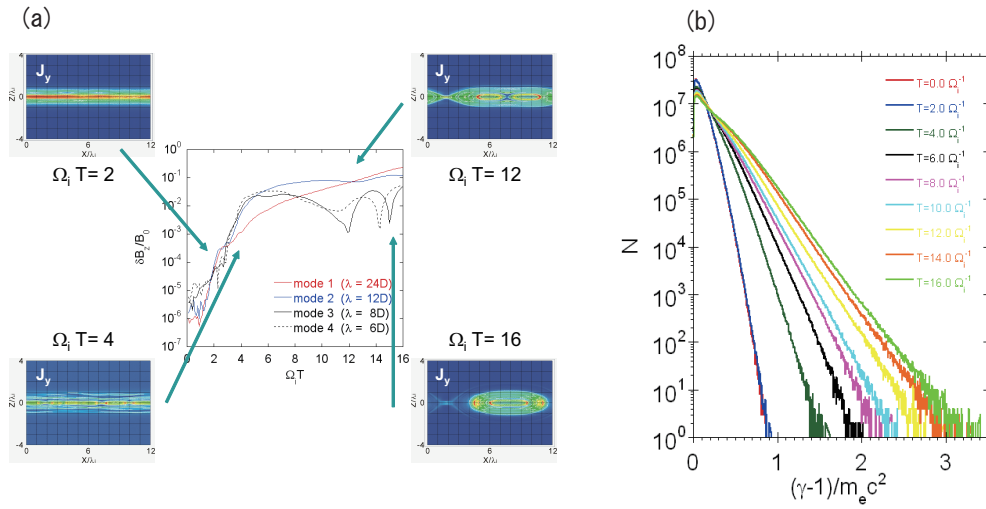

Figure 1: An example of the 3D simulation results. (a) A time history of magnetic island coalescence. The color contours represent the cross-field electron current density. (b) Electron energy spectra obtained during magnetic island coalescence.

Oral Session

November 16

T. Amari¹

¹*CNRS, Centre de Physique Théorique de l'École Polytechnique*
amari@cpt.polytechnique.fr

Mechanisms and Kinematics of Coronal Mass Ejections

Bernhard Kliem

Astrophysical Institute Potsdam, Germany

bkliem@aip.de

The currently discussed mechanisms of coronal mass ejections (CMEs) differ in the assumption of the relevant magnetic topology at onset (sheared arcade vs. twisted flux rope) and in the role ascribed to magnetic reconnection (main driver vs. main trigger vs. consequence of ideal MHD instability or catastrophe). I will discuss the flux rope instability/catastrophe model, the driven flux rope model, the tether cutting model, and the breakout model, emphasizing their similarities: they all involve a flux rope from some stage onward and they all involve magnetic reconnection. The large fraction of CMEs that show an exponential or near-exponential rise profile and the clearly super-Alfvénic velocities reached by some CMEs indicate that an ideal MHD process, probably a flux rope instability or catastrophe, is the primary driving agent. The observed correlation between the CME velocity/acceleration profile and the X-ray flux, as well as numerical simulations, suggest that magnetic reconnection is closely coupled with the ideal driver, however. Reconnection provides a positive feedback to the ideal driver via the upward reconnection outflow jet and by adding poloidal flux to the flux rope.

This concept is supported by recent numerical simulations of unstable flux ropes with reconnection included, which have provided very close matches to the observed rise profiles for a (still small) number of eruptive events, ranging from a failed filament eruption to the fastest CME on record. The expansion of a flux rope by the recently proposed torus instability (TI) will be emphasized in particular. The TI describes the rise of CMEs on the coronal scale (from active region sizes up to several solar radii) and it provides a unifying mechanism for fast and slow CMEs, naturally driving fast CMEs from active regions and slow CMEs from extended prominence eruptions in more quiet locations. While it nominally yields exponential rise profiles, it can mimic also power-law rise behavior in the initial phase of eruptions for certain parameter combinations. This will be demonstrated by comparing numerical simulations of TI-unstable flux ropes with two erupting filaments observed by the *TRACE* satellite.

Three dimensional Magnetohydrodynamic modeling of Coronal Mass Ejections

D. Shiota^{1,2}, K. Kusano², T. Miyoshi³, N. Nishikawa⁴, and K. Shibata¹

¹ *Kwasan and Hida Observatories, Kyoto Univ., Kyoto, JAPAN,*

² *The Earth Simulator Center, JAMSTEC, Yokohama, Kanagawa, JAPAN,*

³ *Faculty of Science, Hiroshima Univ. Higashi-Hiroshima, Hiroshima, JAPAN,*

⁴ *JAMSTEC, Yokohama, Kanagawa, JAPAN,*

shiota@kwasan.kyoto-u.ac.jp

Solar flares and coronal mass ejections (CMEs) are the most energetic explosive phenomena in the solar corona, and they exert a great influence on the geomagnetic environment. Recent observations by solar satellites such as *Yohkoh* revealed many pieces of evidence of magnetic reconnection in not only solar flares and also other kinds of explosive phenomena. Based on these results, Shibata (1996, 1999) suggests that CMEs and flares can be understood according to a unified view: mass ejection and magnetic energy release via magnetic reconnection. Although it is widely believed that magnetic reconnection occurs in solar flares and other kinds of explosive phenomena, it remains still unclear what mechanism triggers the reconnection. The relation between flares and CMEs is also unknown.

In order to investigate these questions, we have developed a new three dimensional MHD simulation code, in which a domain is discretized with a spherical geometry. Ideal MHD equations are time-integrated with finite volume method with HLLD non-linear Riemann solver (Miyoshi & Kusano 2005). Initial magnetic field is given by a potential field, which is calculated from arbitrary normal component on the inner surface, as shown in Figure 1.

In this paper, we present the detail properties of the new MHD code and its test results. Furthermore, eruption models of Amari et al. (2003a, 2003b) are adapted with some patterns of ambient potential magnetic field, and the variation in evolution among the models will be discussed.

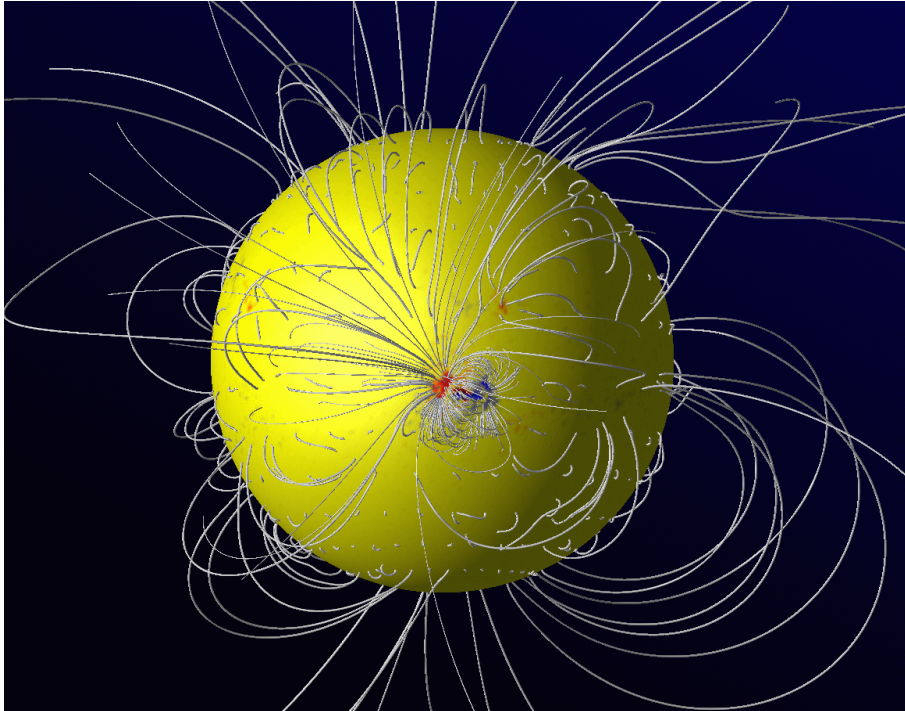

Figure 1: Three dimensional view of an example of potential magnetic field (calculated from MDI synoptic map of September 15, 2005).

Scientific Model Developments Needed to Mitigate Space Weather Impacts

T. G. Onsager¹

¹ NOAA Space Environment Center, Boulder, Colorado, USA

terry.onsager@noaa.gov

Space weather impacts occur due to a complex chain of interactions involving solar processes, the solar wind, the magnetosphere, the ionosphere, and the upper atmosphere. An important challenge for solar-terrestrial physics research is to advance our understanding of the Sun-Earth system and to develop models to the level where timely and accurate predictions of space weather can be made that result in benefits to society. For this to occur, the information provided by these models must be directly usable and must enable decisions to be made that have positive economic consequences. Although much of what is needed today for important applications, such as forecasts of solar energetic particle events, is well beyond the scope of current scientific capabilities, there are a number of ways in which current models could be used to provide valuable, probabilistic space weather forecasts. This presentation will focus on our current understanding of the specific needs for space weather information and the current capabilities of our scientific models. We will explore the overlap between emerging scientific capabilities and space weather needs.

Progress and Challenges Modeling the Geospace Environment

J. Raeder¹, J. C. Dorelli¹, D. Larson¹, and E. Kaghashvili¹

¹ *Space Science Center, University of New Hampshire, Durham, NH 03824, USA*

J.Raeder@unh.edu

The near Earth space environment, also known as “Geospace”, consists of a number of regions which, although they are all populated by magnetized plasmas, have vastly different characteristics. For example, typical particle energies range from a fraction of an eV in the ionosphere and plasmasphere to tens of MeV in the radiation belts. Likewise, the scales of plasmaphysical processes range from a few meters Debye length to the system size of tens of Earth radii. No single code can capture this range of parameters and thus coupled codes are necessary to cover all relevant processes. In this talk we will outline how geospace codes, in particular the OpenGGCM, are constructed, what contemporary codes are capable of, and which challenges we still face. Two specific examples of recent progress, the simulation of flux transfer events (FTEs), and the simulations of tail reconnection events and their connection to auroral poleward boundary intensifications (PBIs) will be presented. These examples show that numerical resolution has only now reached a point where detailed and realistic simulations like these become possible.

An MHD Simulation of the Solar Wind-Magnetosphere Interaction on Substorms and Magnetospheric Storms

T. Ogino¹, T. Aoyama¹ and K. Fukazawa¹

¹ *Solar Terrestrial Environment Laboratory, Nagoya University, Nagoya, Aichi, JAPAN,*
ogino@stelab.nagoya-u.ac.jp

There are typical two kinds of interplanetary disturbances in the solar wind, which are called as ICME (Interplanetary Coronal Mass Ejection) and CIR (Corotating Interaction Region). Generally the former is frequently associated with occurrences of magnetospheric storms and the latter does not usually induce large magnetospheric storms but has often big chance of generation of high energy particles in the radiation belts. Thus it becomes important to simulate responses of the earth's magnetosphere by ICME and CIR to compare the effects. A three-dimensional global MHD simulation of the interaction between the solar wind and the earth's magnetosphere has been executed to study the magnetospheric storm event on space weather problem in October, 2003, when an abnormal operation happened in a satellite for Environment Observation Technology, ADEOS-II (Midori-II) and also to study the CIR event in September, 2005.

Characteristic features of the magnetospheric storm event in 2003 are the long duration of southward IMF, arrival of a strong shock wave, then large variation of IMF B_y from negative to positive for about 15 minutes duration. In the simulation, the shock wave compresses the magnetosphere for southward IMF and high energy plasmas were injected around the geosynchronous orbit from plasma sheet. During the interval when IMF B_y changes from negative to positive, the magnitude of IMF extremely decreases to bring attenuation of magnetic reconnection at the dayside magnetopause. The open-closed boundary shrinks in the polar cap and the transient expansion of the magnetic field lines occurs to imply enhancement of particle precipitation. The reconnection site moves from dawn to dusk at the dayside magnetopause and a narrow cockscomb closed field region is formed in the high latitude tail when the IMF turned from dawn to dusk during northward IMF. Characteristic features of the CIR event in 2005 are characterized by fluctuations of the IMF B_z component and high speed of the solar wind. We will compare the difference of magnetotail dynamics from the global MHD simulation in connection with magnetic reconnection.

The addition of the B_x component to the IMF creates dawn-dusk and north-south asymmetry to the dayside magnetic reconnection. Reconnected open field lines on the dusk side become relatively straight. They increase the lobe magnetic pressure and compress the plasma sheet. Open field lines on the dawn side are bent sharply and decrease the lobe magnetic pressure. As a result tail reconnection occurs preferably on the dusk side. This tendency is enhanced when the IMF is large and the solar wind Alfvén Mach number becomes lower. In such a case, magnetic reconnection frequently occurs in an intermittent and patchy manner. Thus a turbulent structure can be formed in the plasma sheet. The dawn-dusk and north-south asymmetries cause an inclined plasma sheet, rotation of the magnetotail and asymmetric plasma flows in the tail. We demonstrate how reconnection and convection electric fields can be separated in the complicated configuration, and also we present what peculiar magnetospheric configuration is formed for extreme solar wind and IMF conditions.

Modeling the Inner Magnetosphere

Mei-Ching Fok¹

¹ *NASA Goddard Space Flight Center, USA*

mei-ching.h.fok@nasa.gov

The inner magnetosphere is the key element in global space weather modeling. It connects the external solar wind to the inner-most bulk of the ionosphere and atmosphere. A considerable part of solar wind energy and momentum dissipated to the Earth is through the inner magnetosphere. The inner magnetosphere itself is also the dwelling place for many satellites. Therefore, an understanding of the plasma and electro-dynamics of the inner magnetosphere sufficient to perform successful prediction has significant scientific benefits and space weather relevance. Great progress has been made in recent years in modeling the ring current and radiation belts, the energetic plasma populations in the inner magnetosphere. The simulation models have evolved toward a coherent approach that considers the solar wind driver, coupling between different plasma populations in the magnetosphere as well as connections with the ionosphere. On the other hand, even with increasing complexity, many simulation models are now run on fast parallel machines capable of providing now-casting and forecasting of the space environment. One of the most important effects to be introduced within global models is the radial redistribution of the ionosphere resulting from energy dissipation within it. Future challenge in modeling the inner magnetosphere includes consideration of all important physical processes in efficient ways so that real time modeling can accurately describe and predict global space weather from Sun to ground.

MHD and ring current simulations of a superstorm on 20 November 2003

R. Kataoka¹, D. H. Fairfield², D. G. Sibeck², L. Rastaetter², M.-C. Fok²,
T. Nagatsuma³, and Y. Ebihara⁴,

¹ *STE Laboratory, Nagoya University, Nagoya, Aichi, Japan,*

² *NASA Goddard Space Flight Center, Greenbelt, Maryland, USA,*

³ *National Institute of Information and Communications Technology, Koganei, Tokyo, Japan,*

⁴ *National Institute of Polar Research, Itabashi, Tokyo, Japan*

ryuho@stelab.nagoya-u.ac.jp

Energy transfer from the solar wind into the magnetosphere and ionosphere is controlled by the southward magnetic field in the magnetosheath which under normal high Mach number conditions is about four times the solar wind southward field. In a low Mach number regime, however, the magnetosheath compression is diminished by a low solar wind density when the magnetic field remains steady. When magnetic clouds with extremely strong magnetic field cause severe geomagnetic storms under such low Mach number conditions, the density control of the energy transfer is expected to be important in understanding ring current evolution. Here we show evidence for such a density effect using in-situ observation by the GOES and Cluster spacecraft in the magnetosheath during the main phase of the super storm on 20 November 2003. Results from a global magnetohydrodynamic (MHD) simulation with an embedded ring current simulation also support this density effect.

Real-time global MHD simulation of the solar wind interaction with the earth's magnetosphere

H. Shimazu^{1,2,5}, T. Tanaka^{2,3,5}, S. Fujita^{4,5}, M. Nakamura^{1,5}, H. Shinagawa^{1,2,5}, and T. Obara^{1,5}

¹ *National Institute of Information and Communications Technology, Koganei, Tokyo, JAPAN,*

² *Space Environment Research Center, Kyushu University, Fukuoka, JAPAN,*

³ *Department of Earth and Planetary Sciences, Kyushu University, Fukuoka, JAPAN,*

⁴ *Meteorological College, Kashiwa, Chiba, JAPAN,*

⁵ *CREST, JST*

shimazu@nict.go.jp

We have developed a real-time global MHD simulation of the solar wind interaction with the earth's magnetosphere. By adopting the real-time solar wind parameters including the IMF observed routinely by the ACE spacecraft, responses of the magnetosphere are calculated with the MHD code. We adopted the modified spherical coordinates, and the mesh point numbers for this simulation are 56, 58, and 40 for the radial, latitudinal, and longitudinal direction, respectively. The simulation is carried out routinely on the super computer system at National Institute of Information and Communications Technology, Japan. The visualized images of the magnetic field lines around the earth, pressure distribution on the meridian plane, and the conductivity and potential on the polar ionosphere, can be referred to on the Web site (<http://www.nict.go.jp/y/y223/simulation/realtime/>).

The results show that various magnetospheric activities are almost reproduced qualitatively. They also give us information how geomagnetic disturbances develop in the magnetosphere in relation with the ionosphere. From the viewpoint of space weather, the real-time simulation helps us to understand the whole image in the current condition of the magnetosphere. To evaluate the simulation results, we compare the AE index derived from the simulation and observations. In the case of isolated substorms, the indices almost agreed well in both timing and intensities. In other cases, the simulation can predict general activities, although the exact timing of the onset of substorms and intensities did not always agree. By analyzing the data and comparing them with observations, we believe that the real-time simulation is being improved continuously and approaching a more realistic magnetosphere.

Utilizing the global MHD simulation data, we also trace the trajectories of solar energetic protons from the upstream side of the solar wind. The results show that protons having energies on the orders of 100 keV and 1 MeV that reach the inner magnetosphere could experience shock drift acceleration at the quasi-perpendicular bow shock when the dynamic pressure of the solar wind increases.

A numerical simulation of an overshielding effect of the magnetospheric convection electric field

S. Fujita^{1,4}, T. Kikuchi², and T. Tanaka^{3,4}

¹ *Meteorological College, Kashiwa, Chiba JAPAN*

² *Solar-Terrestrial Research Laboratory, Nagoya University, Nagoya JAPAN*

³ *Department of Earth and Planetary Sciences, Kyushu University, Fukuoka JAPAN*

⁴ *CREST, JST*

sfujita@mc-jma.ac.jp

It is essentially important for the space weather research to investigate responses of the magnetosphere-ionosphere system against solar wind variations by using a realistic global simulation. Among many phenomena as the response such as the substorm (southward turn of IMF) [Tanaka, 2000], a SC (pressure impulse) [Fujita et al., 2003a,b], and the theta aurora (switch of IMF By) [Tanaka et al., 2004], the overshielding of the magnetospheric convection electric field associated with northward turn of IMF has not been studied in detail. Thus, we study the overshielding by using a global MHD simulation.

It is sometimes observed that the electric field associated with the Region-2 (R2) current overcomes the electric field induced from the R1 current. This event is called as the overshielding caused by the R2-current-associated electric field. The overshielding effect appears when the IMF Bz turns northward [Kikuchi et al., 2000]. They discussed that time delay of the R2-currents response to the IMF Bz northward turn against the R1-currents response causes the overshielding effect. We carried out a numerical experiment of the overshielding effect by imposing northward turn of the IMF Bz based of a global MHD simulation of the magnetosphere-ionosphere system [Tanaka, 1995]. The simulation successfully reproduced the overshielding effect due to the R2 current. The time delay of the R2-currents response to the solar wind IMF Bz change against the R1-currents response is about 15 minutes in the simulation results; this is consistent with the observations. By investigating the simulation results, the delayed R2 current is driven by a dynamo near the dayside cusp. This dynamo is generated by sunward plasma flows associated with reconfiguration of the magnetosphere during the northward turn of IMF. The overshielding event is characterized with the transiently enhanced R2 current and the transient plasma convection in the magnetosphere-ionosphere system. This result is harmonized with the enhancement of the FAC and a transient plasma convection in transition of the magnetosphere-ionosphere compound system [Fujita et al., 2005].

References

- [1] Fujita et al., A numerical simulation of the geomagnetic sudden commencement: 1. Generation of the field-aligned current associated with the preliminary impulse, *JGR*, 108, 1416, doi:10.1029/2002JA009407, 2003a.
- [2] Fujita et al., A numerical simulation of the geomagnetic sudden commencement: 2. Plasma processes in the main impulse, *JGR*, 108, 1417, doi:10.1029/2002JA009763, 2003b.
- [3] Fujita et al., A Numerical simulation of the geomagnetic sudden commencement: 3. A SC in the magnetosphere-ionosphere compound system, *JGR*, doi:10.1029/2005JA011055, 2005
- [4] Kikuchi et al., Penetration of auroral electric fields to the equator during a substorm, *JGR*, 23251, 2000
- [5] Tanaka, Generation mechanisms for magnetosphere-ionosphere current systems deduced from a three-dimensional MHD simulation of the solar-wind-magnetosphere-ionosphere coupling processes, *JGR*, 12057, 1995.
- [6] Tanaka, T., The state transition model of the substorm onset, *JGR*, 105, 21081, 2000.
- [7] Tanaka et al., Formation of the theta aurora by a transient convection during northward interplanetary magnetic field, *JGR*, 109, A09201, doi:10.1029/2003JA010271, 2004.

Oral Session
November 17

Modeling and predicting solar cycles using a flux-transport dynamo

M. Rempel¹ and M. Dikpati¹

¹ *High Altitude Observatory, NCAR*

rempe1@hao.ucar.edu

We review recent developments of solar flux-transport models leading to a more comprehensive understanding of convection zone dynamics including the interaction between differential rotation, meridional flow and magnetic field evolution. Based on a non-kinematic model including Lorentz-force feedback on differential rotation and meridional flow we discuss the energetics and non-linear saturation of a flux-transport dynamo. We find that the dynamo saturates at a toroidal field strength of around 10 - 20 kG through the back-reaction on differential rotation. At the same time the back-reaction is not strong enough to switch off the transport of field by the meridional flow that is essential for a flux-transport dynamo. Solar cycle variations of differential rotation and meridional flow resulting from the feedback are compared to helioseismic measurements. In the second part of the talk we present a cycle prediction scheme that is based on a flux-transport dynamo. The scheme is driven by observations through an assimilation of observed magnetic data from cycle 12 until the present. We are able to correctly simulate the relative sequence of peaks of cycles 12-23 and forecast that cycle 24 will be 30-50 percent higher than cycle 23.

Photospheric and coronal activities dynamically produced by flux emergence

T. Magara¹

¹ *Kwasan Observatory, Kyoto University, Kyoto, JAPAN*
magara@kwasan.kyoto-u.ac.jp

Magnetic fields are believed to play fundamental roles in producing various activities in solar atmosphere. These activities potentially have a severe impact on the environment of the Earth. The magnetic fields originally come from the subphotosphere by magnetic buoyancy and the modeling of this process is a key to the understanding of mechanisms for driving those solar activities.

In this study we make an investigation into the features of photospheric motions and coronal magnetic structure dynamically produced by flux emergence. The purpose of this work is to understand how these features are related to the twist of subphotospheric field. Toward this end we examine the emergence of a twisted flux tube by performing a couple of MHD simulations in which we apply different twists to the flux tube as the initial state. We analyze the photospheric flow driven by flux emergence by decomposing it into several fundamental flow components such as rotation, expansion/contraction, and distortion. A particular attention is paid to the evolution of photospheric neutral line that is recognized as a key observational signature of filament formation. Clarifying how to form a filament on the Sun contributes toward increasing our knowledge of how to cause a solar eruption, which is important for space weather. We also investigate how the twist of subphotospheric field affects coronal structure.

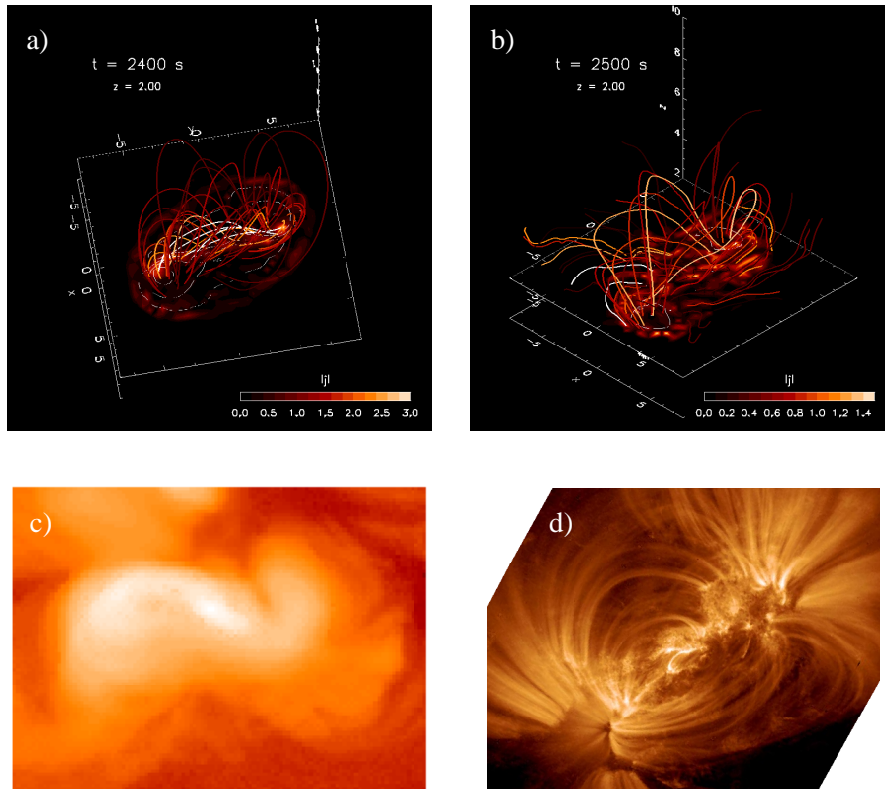

Figure 1: (a) A snapshot of emerging field lines obtained from the simulation (highly twisted case). The color map shows current density $\mathbf{j} = \nabla \times \mathbf{B}$ in a chromospheric plane while contours in this map represent vertical magnetic flux. Line colors represent the strength of current density at the footpoint of those field lines in this plane (bright color indicates that high current density is distributed at the footpoint). (b) Same as (a) except for the weakly twisted case. (c) A soft X-ray image of a sigmoid obtained by *Yohkoh*. (d) An EUV image of expanded coronal loops obtained by *TRACE*.

CORRELATION BETWEEN SOLAR FLARE PRODUCTIVITY AND PHOTOSPHERIC MAGNETIC FIELD PROPERTIES

Huaning Wang, Yanmei Cui, Rong Li, Liyun Zhang and Yulin He

National Astronomical Observatories,

Chinese Academy of Sciences

hnwang@bao.ac.cn

There are physical several measures to be used to describe photospheric magnetic field properties including nonpotentiality and complexity, which is believed to be closely related to solar flares. From a large number magnetograms during the 23th solar cycle, we study the correlation between solar flare productivity and photospheric magnetic field properties. Our statistical results demonstrate that solar flare productivity increases with nonpotentiality and complexity. Furthermore, the relationship between the flare productivity and these measures can be well fitted with sigmoid function. These results will be beneficial to future operational flare forecast models.

Anemone Structure and Geo-Effective Flares/CMEs

Ayumi Asai¹, Takako T. Ishii², Kazunari Shibata², and Nat Gopalswamy³

¹ Nobeyama Solar Radio Observatory, NAOJ, Nobeyama, Nagano, 384-1305, JAPAN,

² Kwasan and Hida Observatories, Kyoto University, Yamashina, Kyoto, 607-8471, JAPAN,

³ NASA/GSFC, Greenbelt, MD20771, USA

asai@nro.nao.ac.jp

We present a detailed examination of the features of the Active Region (AR) NOAA 10798. The AR generated geo-effective flares that caused a large geomagnetic storm on 2005 August 24 with the Dst index of -216 nT. We examined the evolution of the AR and the features on/near the solar surface, by analyzing the data of the photosphere, the chromosphere, and the corona.

The AR emerged in the middle of a small coronal hole, and formed a *sea anemone* like configuration. $H\alpha$ filaments were formed in the AR, which have southward axial field. Three M-class flares occurred on 2005 August 22, and they were followed by extremely fast CMEs. The speed of the second CME was especially fast, and about 2400 km s^{-1} , which caught up and merged with the first CME. These caused strong southward magnetic field in the inter planetary space, and finally produced a large geo-magnetic storm.

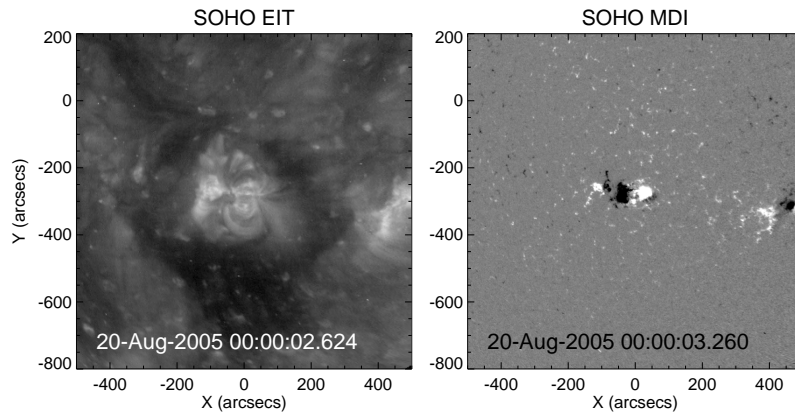

Figure 1: *Sea anemone* like structure of the AR. *Left*: An extreme ultraviolet image taken with SOHO/EIT. The AR is surrounded by a small coronal hole (the darker region). *Right*: A magnetogram taken with SOHO/MDI. The white and the black show the positive and the negative magnetic polarities, respectively.

Forecasting Space Weather with Dynamic Coronal Models

B. T. Welsch¹, G. H. Fisher¹, W. P. Abbett¹, D. W. Longcope², R. Belur²

¹ Space Sciences Laboratory, University of California, Berkeley

² Department of Physics, Montana State University, Bozeman

welsch@ssl.berkeley.edu

Predicting the initiation of eruptive events is the primary unsolved problem in space weather forecasting. In the accepted "storage and release" paradigm of solar flare and coronal mass ejection (CME) initiation and driving, free magnetic energy stored in the coronal magnetic field is suddenly released in flares/CMEs. In accordance with this picture, several techniques to estimate the instantaneous free magnetic energy in the coronal field have been developed; unfortunately, these models have been largely unsuccessful as forecasting tools. A distinct problem is determining whether a given event, once it has begun, will produce adverse effects — for instance, energetic particles that can damage assets, or a strong geomagnetic response. The proper way to tackle both of these problems is with time-dependent simulations of the coronal magnetic field that include a realistic photospheric boundary, driven to match the evolution observed in vector magnetograms. The RADMHD code, recently developed at UCB/SSL by W.P. Abbett for this purpose, can achieve the necessary stratification in density and temperature (Figure 1., top panels), for use in data-driven simulations of active region field evolution (Figure 1., bottom panels).

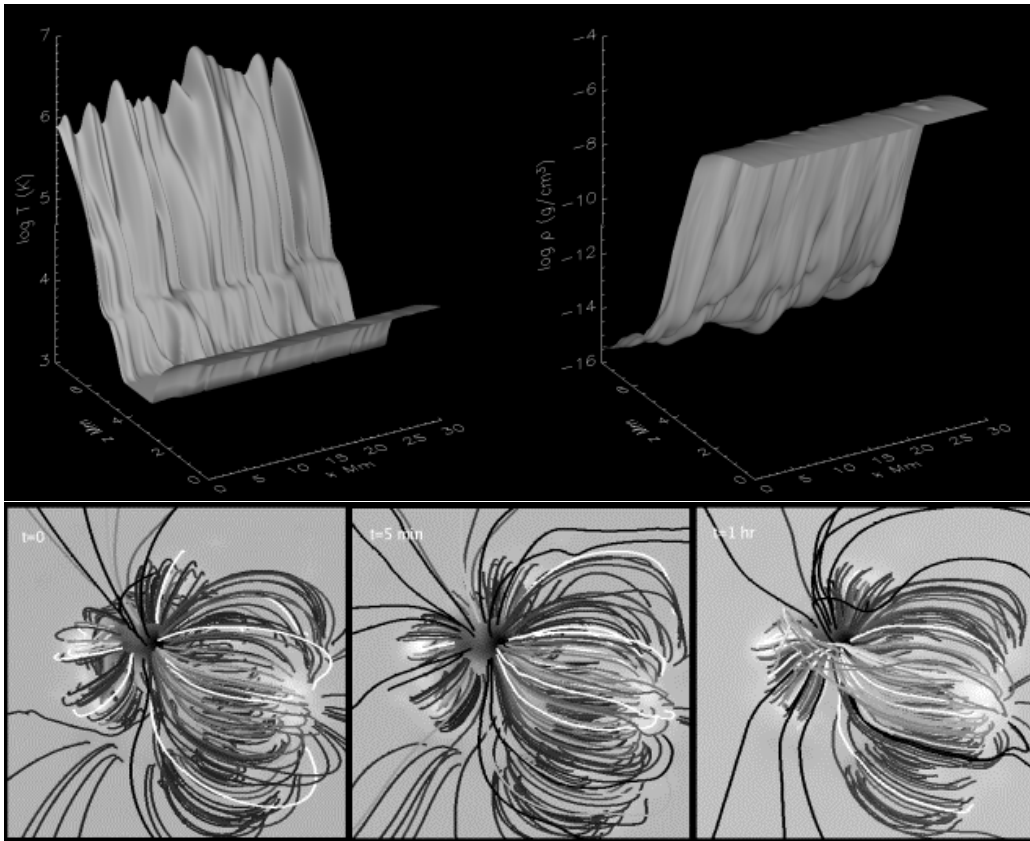

Figure 1: Top: The stratification in density and temperature achieved by the RADMHD code, developed at UCB/SSL by W.P. Abbett. Bottom: A data-driven simulation of field evolution of AR 8210 using this code.

Forecasting Solar Wind Speeds

Takeru K. Suzuki¹

¹ Graduate School of Arts & Sciences, University of Tokyo, Komaba, Meguro, Tokyo, JAPAN
stakeru@ea.c.u-tokyo.ac.jp

By explicitly taking into account effects of Alfvén waves, we derive, from a simple energetics argument as well as magnetohydrodynamical simulations, a fundamental relation which predicts solar wind speeds in the vicinity of the earth from physical properties on the sun. Kojima et al. recently found from their observations that a ratio of surface magnetic field strength to an expansion factor of open magnetic flux tubes is a good indicator of the solar wind speed. We show by using the derived relation that this nice correlation is an evidence of the Alfvén wave which accelerates solar wind in expanding flux tubes (Figures 1). The observations further require that fluctuation amplitudes of magnetic field lines at the surface should be almost universal in different coronal holes, which needs to be tested by future observations.

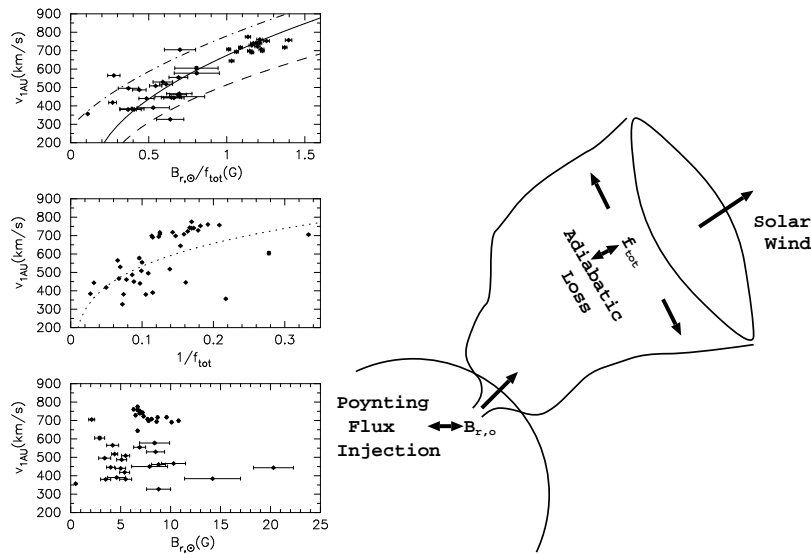

Figure 1: The left panels show relations between SW speeds at $r \simeq 1AU$, v_{1AU} , and properties of magnetic flux tubes. Observed data are from Kojima et al. (2005). Coronal magnetic fields are extrapolated from surface magnetic field strength, $B_{r,\odot}$, by the potential field-source surface method (Hakamada & Kojima 1999). The flux tube expansion, f_{tot} , is derived from comparison between the areas of open coronal holes at the photosphere and at the source surface ($r = 2.5R_{\odot}$). v_{1AU} is obtained by interplanetary scintillation measurements. v_{1AU} , $B_{r,\odot}$, and f_{tot} are averaged over the area of each coronal hole and the data points correspond to individual coronal holes. (Top) : v_{1AU} on $B_{r,\odot}/f_{max}$. Lines are theoretical prediction (Suzuki 2006). Solid line indicates the standard case Dot-dashed line adopt higher coronal temperature Dashed line adopt smaller amplitude at the surface (see Suzuki 2006 for detail). (Middle) : The same data are plotted in $1/f_{tot} - v_{1AU}$ plane. Dotted line is also the result of Suzuki(2006) adopting the similar conditions to those considered in Wang & Sheeley (1991). (Bottom) : The same data are plotted in $B_{r,\odot} - v_{1AU}$ plane. The right cartoon indicates schematic picture of SW in a magnetic flux tube which is super-radially open. $B_{r,\odot}$ is proportional to Poynting flux input from the surface. f_{tot} determines adiabatic loss in the flux tube. Therefore, the kinetic energy of the SW in the outer region is inferred to have positive dependence on $B_{r,\odot}$ and negative dependence on f_{tot} .

- Hakamada, K. & Kojima, M. 1999, Sol. Phys., 187, 115
- Kojima, M., K. Fujiki, M. Hirano, M. Tokumaru, T. Ohmi, and K. Hakamada, 2005, "The Sun and the heliosphere as an Integrated System", G. Poletto and S. T. Suess, Eds. Kluwer Academic Publishers, 147
- Suzuki, T. K. 2006, ApJ, 640, L75
- Wang, Y.-M. & Sheeley, Jr, N. R. 1991, ApJ, 372, L45

**Solar wind control of plasma number density in the near-Earth plasma sheet:
Coordinated study of WIND-ACE/GEOTAIL observations**

D. Nagata¹, S. Machida¹, S. Ohtani², Y. Saito³, T. Mukai³

¹ *Department of Geophysics, Graduate school of Science, Kyoto University, Kyoto, JAPAN,*

² *Applied Physics Laboratory, Johns Hopkins University, Laurel, MD, USA,*

³ *Institute of Space and Astronautical Science, JAXA, Sagami-hara, Kanagawa, JAPAN*

nagata@kugi.kyoto-u.ac.jp

Terrestrial plasma sheet is a storage of plasma which feeds ring current, hence storage property of plasma sheet is important for space weather modeling. Plasma sheet number density N_{ps} is controlled by solar wind. The dependence is known as $N_{ps} = N_0 \exp(\alpha bz) N_{sw}^\gamma$, where bz is IMFBz and N_{sw} is solar wind number density. There is also a time lag between IMFBz and N_{ps} .

In this paper we investigated XY distribution of α , γ , and time lag based on WIND, ACE, and GEOTAIL observations. α and γ are small in the near-Earth region and large in the midtail flank region. α and γ have weak dawn-dusk asymmetry. On the other hand, time lag has strong dawn-dusk asymmetry. A peak of time lag occurs in the dusk flank region ($X=-15\text{Re}$) and its value is 9 hour.

To understand dawn-dusk asymmetry of the time lag, we estimated diffusion time scale and advection time scale based on diffusion-advection equation and plasma flow observations made by GEOTAIL. Diffusion coefficient was calculated under Markov assumption. We found diffusion time scale is 15 hour and advection time scale is 2 hour around the peak of time lag. In the global plasma flow pattern, V_x reverses its direction and flow speed is decreased there. We suggest that the peak of time lag is due to turbulent diffusion in the flow reversal region.

Particle simulation of VLF triggered emissions - roles of the nonlinear cyclotron resonant interaction in the wave generation process

Yuto Katoh^{1,2} and Yoshiharu Omura¹

¹ *Research Institute for Sustainable Humanosphere, Kyoto University, Uji, Kyoto, JAPAN,*

² *Now at Planetary Plasma and Atmospheric Research Center, Graduate School of Science, Tohoku University, Sendai, Miyagi, JAPAN*

yuto@pparc.geophys.tohoku.ac.jp

Observations both on the ground stations and onboard satellites reveal that narrow band whistler mode waves are periodically generated by triggering waves which are emitted from the ground station at high latitude region. These secondary generated waves of frequency of VLF band are known as VLF triggered emissions, and they often consist rising tones. It has been widely recognized that there is a close relationship between the triggering mechanism of VLF triggered emissions and the generation process of whistler-mode chorus emissions, which is closely related to the energizing process of MeV electrons in the Earth's radiation belt.

Recent studies has suggested that the triggering mechanism is deeply related to the nonlinear cyclotron resonance between narrow band whistler mode waves and energetic electrons. Both wave amplitude and wave frequency of coherent whistler mode waves are strongly affected by nonlinear resonant currents formed by resonant electrons in an inhomogeneous magnetic field. Although the frequency rising/falling of triggered emissions have been reproduced by several models, there are unresolved problems of the triggering process because the previous models assumed only a single monochromatic (or band-limited) waves.

In the present study, we carry out a self-consistent particle simulation with a dipole magnetic field to study the generation mechanism of VLF triggered emissions. The evolution of a wave packet propagating along a reference magnetic field line is solved by Maxwell's equations while the bounce motion of energetic electrons in the non-uniform magnetic field is taken into account. Simulation result shows that a triggered emission with a rising tone is generated at the trailing edge of the triggering wave packet. The generation process is explained by roles of resonant currents J_E and J_B in association with an electromagnetic electron hole in the phase space produced through the nonlinear interaction. We find that these resonant currents in the simulation result are formed by untrapped electrons through the nonlinear wave-particle interaction and suggest that the phase bunching of untrapped electrons plays an essential role in the triggering mechanism. We also discuss the effect of the background plasma condition on the wave characteristics of triggered emissions so as to clarify the essential physics of the generation mechanism.

Predictability of Solar Flare Onset and Multi-scale Modelings for Space Weather Dynamics

K. Kusano,¹ T. Sugiyama,¹ H. Hasegawa,¹ D. Shiota,^{1,2} T. Miyoshi,³ and S. Inoue⁴

¹ *The Earth Simulator Center, JAMSTEC, Yokohama, JAPAN*

² *Kwasan and Hida Observatories, Graduate School of Science, Kyoto University, Kyoto, JAPAN*

³ *Graduate School of Science, Hiroshima University, Higashi-Hiroshima, JAPAN*

⁴ *Solar-Terrestrial Environment Laboratory, Nagoya University, Nagoya, JAPAN*

kusano@jamstec.go.jp

Space weather phenomena are related to several explosive dynamics, which can be caused by the abrupt liberation of free magnetic energy stored in preceding quasi-static phase. The onset of solar flares, the launching of Coronal Mass Ejections (CMEs) and a geomagnetic substorm onset are such typical events. The prediction of these events is greatly important for forecasting space weather as well as for advancement in our understanding of complex plasma dynamics. The numerical simulation and modeling driven by integrated observations are a promising methodology for this purpose, although they are still on preliminary level both in solar and magnetospheric applications.

This talk is composed of two parts. In the first part, we focus ourselves on the study on the onset of solar flares. Since magnetic helicity is a measure of magnetic flux linking, and a proxy of magnetic free energy, it has been widely believed to play a crucial role for the storage-and-release dynamics of magnetic energy in the solar corona. Recently, several new techniques have been proposed to measure the magnetic helicity injection through the photosphere into the corona, and using the new methods it has been revealed that not only the amplitude but also the structural complexity in magnetic helicity well correlate to the energetic activity of the solar corona. Numerical modeling driven by theoretical thought as well as by observed data is a powerful tool to understand the mechanism of correlation between flares and magnetic helicity. By reviewing the recent works relating to this problem, we will discuss about the predictability of the onset of solar flares in terms of the numerical models.

In the second part, our new effort to develop the novel numerical technique for multi-scale simulation will be presented. The fact that the explosive events suddenly commence implies that very small scale structure should be involved in the explosive space weather dynamics, which is originally governed by large scale magnetohydrodynamics (MHD). For instance, micro-scale kinetic processes could play a key role in magnetic reconnection, which must be a crucial process for the energy liberation in solar flares. Also the particle acceleration triggered by MHD shock is another example for the multi-scale events. We are developing a new methodology so-called "Macro-Micro Interlocked (MMI) simulation" in order to handle the mutual interaction between multi-scale processes self-consistently. The MMI simulation for space weather applications is performed by interlocking the MHD-based macro-scale model and the particle-in-cell (PIC) based micro-scale model. The availability and the practicability of the MMI simulation are demonstrated by applying it to reconnection and auroral arc formation problems, respectively. Based on the results of them, we will discuss also about the prospective subjects in advanced modeling of space weather events.

MHD-PIC Interlocked Simulation Model for Magnetic Reconnection

T. Sugiyama¹ and K. Kusano¹

¹ *Earth Simulator Center, JAMSTEC, Yokohama, Kanagawa, JAPAN*

tsugi@jamstec.go.jp

Although many kinds of simulation models have been developed to understand the complex plasma systems, the physical process and the spatial-temporal scales must be restricted by the fundamental assumption of each model. However, the interaction across multiple scales may play a crucial role in some plasma phenomena. Magnetic reconnection process is the typical example, where the kinetic process in the micro-scale instability may interact with the large scale magnetohydrodynamics (MHD). We have developed the new simulation model, in which the interaction between the macroscopic and microscopic processes is able to be taken into account self-consistently, by directly interlocking the MHD simulation and the particle-in-cell (PIC) simulation models. The MHD-PIC interlocked model is first applied to the study of the auroral arc formation process, in which both the Alfvén wave resonance instability and the electron acceleration in the double layer structure formed by the ion-acoustic instability are calculated simultaneously. It is our great challenge to establish the interlocked simulation framework which is applicable in many fields. Here, we will present another example of the MHD-PIC interlocked model for the magnetic reconnection process. Since the kinetics in the magnetic diffusion region is so important as to determine the reconnection rate and the trigger activity of reconnection, therefore, the PIC simulation must be used in this region. On the other hand, the large-scale configuration of the anti-parallel magnetic field and the plasma conditions surrounding the diffusion region are crucial for the creation of the diffusion region as well as for the subsequent reconnection dynamics. The dynamics in the global-scale are well modeled by the MHD simulation. These well characterized points in both MHD and PIC models are efficiently utilized by being simultaneously calculated. Our simulation model can well interlock the micro kinetics of PIC and the macro conditions of MHD. In this presentation, we will explain the algorithm of the new model how we interlock the MHD and PIC models in the simulation, and show the results of that, which has been calculated in the Earth Simulator.

Polynomial interpolation for hyperbolic conservation laws (PIC) scheme: Application to Vlasov Simulations

Takayuki Umeda

Solar-Terrestrial Environment Laboratory, Nagoya University, Nagoya, Aichi, JAPAN
umeda@stelab.nagoya-u.ac.jp

We discuss numerical interpolation schemes used in Vlasov simulation codes. Due to their low noise level, Vlasov codes are widely used for studies of nonlinear wave-particle interactions in plasmas. The numerical methods for solving Vlasov-Maxwell equations fall into two groups. One is particle-in-cell (PIC) simulation which follows motions of individual particles in a self-consistent electromagnetic field. However, limitation of number of superparticles gives rise to numerical thermal fluctuations. Another approach is Vlasov simulation which integrate distribution functions defined in the position-velocity phase-space. An advantage of Vlasov codes is that we can suppress the thermal fluctuations which are strongly enhanced in PIC simulations. In recent Vlasov simulation codes Vlasov-Maxwell equations are solved based on the numerical interpolation method because of its simplicity of algorithm and easiness for programming. However, we need a large number of grid points in both configuration and velocity spaces to keep mass conservation and to suppress numerical diffusion. In the present study we developed new Vlasov codes with recent higher-order interpolation schemes. We compared the interpolation schemes for a long-time nonlinear problem with respect to numerical diffusion, stability, mass and energy conservations.

We solved the Vlasov equation with the time-advance algorithm called “splitting method” (Cheng & Knorr, 1976). To solve the advection equations split from the Vlasov equation, we used several different numerical interpolation schemes. We found that the mass conservation is an important feature in Vlasov simulations that has a direct influence on the energy conservation. In the present study we propose a new Non-Oscillatory (NO) numerical interpolation scheme for Vlasov simulations, which is called Polynomial Interpolation for hyperbolic Conservation laws (PIC) scheme. The NO-PIC scheme has advantages in numerical stability, computing speed, shape preservation, and energy conservation in Vlasov simulations.

Magnetic Reconnection in Large and Fully Kinetic System

Keizo Fujimoto^{1,2} and Takahiro Obara²

¹ *University of Alberta, Edmonton, Alberta, CANADA,*

² *NiCT, Koganei, Tokyo, JAPAN*

fujimoto@phys.ualberta.ca

Understanding the mechanisms of the magnetospheric substorm and solar flares is crucial for improving space weather prediction. Magnetic reconnection is one of the key processes playing an important role in these phenomena, which enables fast energy release of the magnetic energy into plasma kinetic and thermal energies. However, many of detailed processes around the diffusion region are poorly understood. One of the main questions about magnetic reconnection is whether it is possible to achieve the energy release fast enough to explain the timescales seen in physical system. Previous studies have constructed a model, in which the inclusion of Hall effects is a sufficient condition to realize fast reconnection. The importance of the Hall effects has been confirmed by comparing MHD, Hall MHD, hybrid, and full particle simulations. However, the systems do not reach a steady state, because small cyclic systems tend to suppress the reconnection processes. Since it is still very difficult to conduct large-scale simulations using the conventional particle-in-cell (PIC) code, we employed the adaptive mesh refinement (AMR) technique on the PIC code and successfully conducted a large-scale full particle simulation of magnetic reconnection. We found that, though fast reconnection is achieved as shown in the previous simulations, the reconnection rate decreases soon and a quasi-steady reconnection is not realized. The key process responsible for slowing the reconnection processes is the extension of the electron diffusion region toward the outflow direction, which suppresses the electron inflow velocity, that is, the inflow velocity of the magnetic flux. The extension of the electron diffusion region is caused by the enhancement of the polarization electric field and resulting out-of-plane electron current arising in the electron inflow region.

In this paper, we show the results of large-scale full particle simulations and explain the mechanism how the reconnection processes can be slowed down.

Toward the success of space weather predictions

Y. Kamide¹

¹ *Solar-Terrestrial Environment Laboratory, Nagoya University, Nagoya 464-8601, Japan*
kamide@stelab.nagoya-u.ac.jp

This talk tries to summarize the CAWSES International Workshop on SpaceWeather Modeling (CSWM) by providing some of the keywords discussed extensively in the workshop.

Poster Session I

Short Oral Presentation
(November 14 : 15:40 – 16:10)

Core Presentation Time
(November 14 : 16:10 – 17:40)

Expected Performance and Science Modes of the X-Ray Telescope on Solar B

K. Reeves¹ J. Cirtain¹, L. Lundquist¹, M. Weber¹ and the XRT Team

¹ *Smithsonian Astrophysical Observatory, Cambridge, MA, USA*

kreeves@cfa.harvard.edu

The X-Ray Telescope (XRT) on Solar B is a grazing incidence telescope with 1 arcsecond pixels and a field of view big enough to encompass the entire disk of the sun. The filters aboard XRT are designed to cover a broad temperature range in order to observe both high-temperature transient sources and low-temperature persistent sources present in the solar corona. We will discuss the expected throughput of the instrument over this broad temperature range. We will also discuss the different science programs that we expect to run on XRT in order to study variety of coronal structures and events. These programs are designed to explore the dynamics, energetics and topology of fine scale coronal phenomena as well as large scale dynamic events.

Forecast of the Solar Flare Magnitude from the Photospheric Magnetic Field

T. T. Yamamoto¹ and T. Sakurai^{1,2}

¹ *Department of Astronomy, The University of Tokyo, Bunkyo-ku, Tokyo, Japan,*

² *National Astronomical Observatory of Japan, Mitaka, Tokyo, JAPAN*

yamamoto@solar.mtk.nao.ac.jp

The solar flare is a transient phenomenon, and has great influence on the sun-earth environment. It is important to forecast when, where and how a large flare occurs. In this study, we compared solar flare magnitudes and photospheric magnetic properties quantitatively for the purpose of forecasting how large a flare may be. We applied a linear fitting method to the data of photospheric magnetic properties and solar flare magnitudes, and evaluated a simultaneous tolerance interval.

Data samples are composed of 22 flares and 14 active regions. The solar flare magnitude is obtained from the GOES satellite 1-8 angstrom data. The largest and smallest flares in the sample are X17 (1.7×10^{-3} W/cm²) and A5 (5.0×10^{-8} W/cm²), respectively. The photospheric magnetic properties are derived from the vector magnetograms of the Solar Flare Telescope (Mitaka, Japan) and from the SoHO/MDI magnetograms. The photospheric magnetic properties are evaluated by using magnetic flux, magnetic field strength, current density and others. We applied the linear fitting method to the data of the flare magnitudes and the magnetic properties of the regions. In the linear fitting equation a probability and a confidence level are set, and then a simultaneous tolerance interval is obtained. If we use the magnetic field strength and the flare region area as magnetic parameters, a simultaneous tolerance interval is about a factor of 1.8 with 0.90 probability and 0.90 confidence level, and about a factor of 13.8 with 0.95 probability and 0.95 confidence level.

These photospheric magnetic properties are derived from the regions which showed flare brightening. However, it is difficult to forecast where a next flare occurs. So we also use the magnetic properties obtained from strong shear regions and from the entire active regions. In this presentation, we explain these parameters and results in detail.

The trigger mechanism of flares occurred in the most flare-productive active region during Solar Cycle 23

Kaori Nagashima^{1,2}, Takako T. Ishii², Takenori J. Okamoto², Takaaki Yokoyama³, and Kazunari Shibata²

¹ Department of Astronomy, Kyoto University, Kyoto, JAPAN,

² Kwasan and Hida Observatories, Kyoto University, Kyoto, JAPAN,

³ Department of Earth and Planetary Science, University of Tokyo, Tokyo, JAPAN

kaorin@kwasan.kyoto-u.ac.jp

Flare activity on solar surface will affect human life through the disturbances in the interplanetary space and the magnetosphere. Flares are associated with plasma ejections, such as filament eruptions and coronal mass ejections (CMEs). Since a CME is the phenomenon that a massive amount of plasma in the solar corona erupts into the interplanetary space at a high speed and the ejecting plasma will disturb geomagnetic field, a CME tends to cause geomagnetic storms. Therefore, investigating the trigger mechanism of flares is one of the most important subjects in the field of space weather.

NOAA Active Region (AR) 10808, appeared in September 2005, produced at least 10 X-class and 25 M-class flares, which is the most intense flare activity during Solar Cycle 23 though it was in the declining phase of the Cycle. Some large flares, such as an X1.5 class flare on Sep. 13th, were accompanied by filament eruptions and, furthermore, halo CMEs. The geomagnetic storms accompanied by these solar activities were not so strong, however.

We analyze the chromospheric and coronal structures through EUV images obtained by TRACE and the photospheric magnetic field structure using SOHO/MDI magnetograms. Moreover, we also use the H α and its wing images obtained by Solar Magnetic Activity Research Telescope (SMART) at Hida Observatory, Kyoto University to pursue the evolution of this active region in multi-wavelength observation. This region had a delta-type sunspot which has two umbrae with different magnetic polarities packed tightly within a single penumbra, and showed a rotational motion in this delta-type sunspot. We find two sites where flares frequently occurred in the active region: one is on the magnetic neutral line between the umbrae with different polarities and the other is the southeast of the delta-type sunspot. These regions are indicated by black and white circles in figure 1, respectively. We focus on the activities during the preflare phase of several major flares and find some small EUV brightenings prior to the main phase of flares.

In this paper, we will report the precursors of flares and discuss the trigger mechanism of flares in this region.

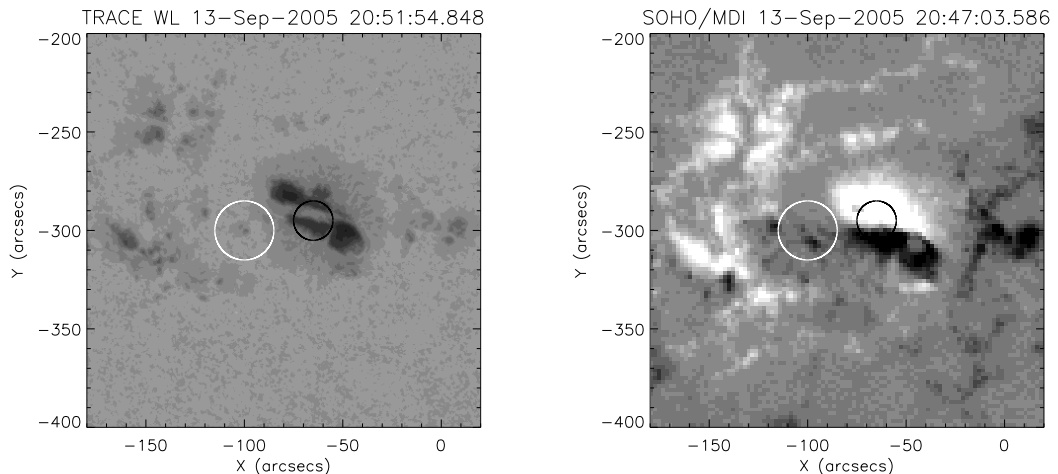

Figure 1: NOAA AR 10808 images. Left panel shows TRACE white-light image and right panel shows SOHO/MDI magnetogram. North is up, and west is to the right. White and black indicate positive and negative polarities in the magnetogram. The black and white circles in both panels indicate the sites where flares frequently occurred.

Coronal Transient Activities Observed with Norikura Green-line Imaging System "NOGIS"

K. Hori and NAOJ NOGIS team¹

¹ *Solar Observatory, National Astronomical Observatory of Japan, Mitaka, Tokyo, JAPAN,*
hor@solar.mtk.nao.ac.jp

We present an overview of solar transient activities in the inner corona (up to 1.5 Rs) observed with NORikura Green-line Imaging System, "NOGIS" (Ichimoto et al. 1999). NOGIS is a 10cm-aperture coronagraph developed at the Norikura Solar Observatory, NAOJ, located at the 2876m summit of Mt. Norikura in the Northern Japan Alps. NOGIS is a unique imaging system that can provide both intensity and Doppler velocity images of 2MK plasma from the coronal green-line emission $\lambda 5303\text{\AA}$ of Fe XIV. The Doppler images are constructed by subtracting a $[\lambda - 0.45\text{\AA}]$ image from a $[\lambda + 0.45\text{\AA}]$ image. The line-of-sight velocity up to $\pm 25\text{ km s}^{-1}$ can be obtained with an accuracy of about 0.6 km s^{-1} . Hence, the target phenomena suitable for NOGIS are coronal waves and flows, rather than fast eruptions heading toward the Earth. NOGIS has a field of view of 2000×2000 pixels in a full frame mode, and a spatial resolution of $1.84''$ in a partial frame mode. Time resolution is reduced to about 1 minute to increase signal-to-noise ratio. Since July 1997, NOGIS has observed many flares, plasma expansions, and coronal waves. We demonstrate how NOGIS's high sensitivity images are useful to investigate the origin of coronal disturbances. By collaborating with Solar-B, we discuss application to the space weather forecast using NOGIS images.

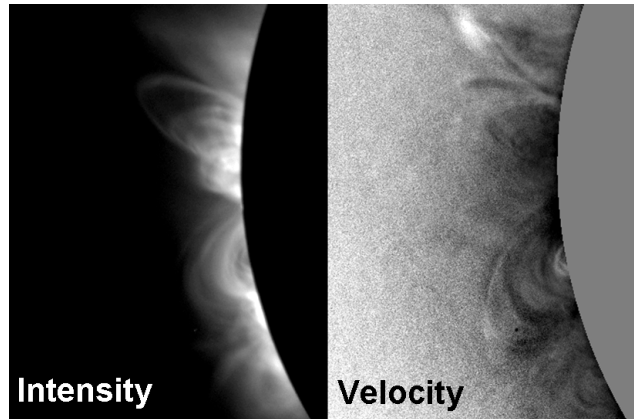

Figure 1: NOGIS partial frame mode images.

*For NOGIS full frame mode images, please refer the item "5303 Angstrom Images" (after 1997) at http://solarwww.mtk.nao.ac.jp/en/db_gline2.html

MHD modeling for global corona

T.Matsumoto¹ and K.Shibata²

¹ *Department of Astronomy, Kyoto University, Kyoto, Kyoto, JAPAN,*

² *Kwasan and Hida Observatories, Kyoto University, Kyoto, Kyoto, JAPAN*

mtakuma@kwasan.kyoto-u.ac.jp

It is important to estimate changes of space environment when human beings are going into space. Especially, solar activities like flares and CMEs play a key role in space weather. Interplanetary space will propagate the disturbances at the solar surface and the disturbances will give various effects on the earth. Therefore it is necessary to understand how the disturbances will change their properties in the interplanetary space.

In order to simulate the solar corona including the solar wind, we develop a three-dimensional magnetohydrodynamic (MHD) spherical coordinate code using CIP-MOCCT scheme. We check the accuracy of our code by solving MHD shock tube problem and B.C.Low (1984) coronal transient problem. Initial conditions of our simulation for ρ, v, P are taken from the spherically-symmetric transonic solution, the so-called Parker solution. Initial conditions for B are taken from the potential field calculated from Michelson Doppler Imager (MDI) photospheric magnetic field (Figure 1).

In this workshop, we will report the steady state solar corona obtained by integrating the MHD equation forward and research the typical coronal structure at solar minimum.

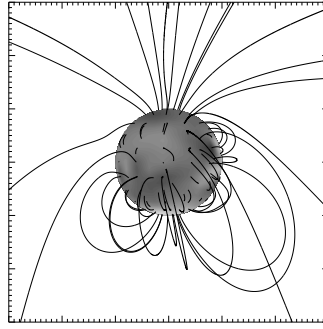

Figure 1: Potential field calculated from MDI photospheric magnetic field on Mar-29-2006.

Study of the Energy Build-up Process in Solar Active Regions by Using the Longitudinal Magnetic Field Observations

T. Yokoyama and S. Notoya

¹ *Department of Earth and Planetary Science, University of Tokyo, Tokyo, JAPAN*
yokoyama.t@eps.s.u-tokyo.ac.jp

One of the most important issues in terms of the solar coronal activities is the energy build-up and trigger mechanisms of such phenomena. The analysis of the observed magnetic field data is a key to understand these processes. The SOLAR-B will provide us an information of the three-components photospheric magnetic field without an interruption with an unprecedented quality. In order to prepare for such opportunities we are developing a method to analyze such development of the magnetic field on the Sun.

In this study, we use the data taken by SOHO/MDI. They include the longitudinal component of the photospheric magnetic field basically without an interruption. Active region NOAA 8100 is analyzed, where many GOES X- and M-class flares and CMEs occurred. It is one of the most popular active regions which is well analyzed by several authors from the viewpoints of helicity injection and energy build-up. The original point of our study is that we follow the motions of the "magnetic patches" that is defined as a patch which has a local maximum in space of longitudinal magnetic field strength. Each patch has approximately a size of 10 arcseconds (≈ 7000 km). The developments of the speed, size, magnetic flux and so on, are derived from a set of the magnetograms. The distances between each pair of such patches with opposite polarities are also monitored as functions of time. They are compared with the positions and times of the flares in this active region. We found that each flare occurred temporally a few hours after a concentration of the magnetic strength gradient beyond a threshold ($\approx 250\text{G/arcsec}$) and spatially close to such a concentration (in 20 arcseconds). This is, however, a necessary condition but not a sufficient condition.

Investigation of the Spatial Correlation between Solar Flare Kernels and Photospheric Magnetic Field Configurations by using the SMART at Hida Obs.

Satoru UENO¹, Masaoki HAGINO¹, Jinping DUN¹, Kenichi OTSUJI¹, Shinichi NAGATA¹, Kaori NAGASHIMA¹, Takako ISHII¹, Reizaburo KITAI¹, Kazunari SHIBATA¹, Kanya KUSANO²

¹ *Kwasan Hida observatories, Graduate school of science, Kyoto University, Takayama, Gifu, JAPAN,*

² *Earth Simulator Center, JAMSTEC, Yokohama, Kanagawa, JAPAN,*

ueno@kwasan.kyoto-u.ac.jp

The observational data of photospheric magnetic field distributions are comparatively easy to observe and they give us a lot of information for considering about the condition for the generation of solar flares. Therefore, they have been researched from various sides up to the present time.

Generally, the flare is said that it tends to occur along the magnetic neutral line or on the region where the shear-angle of the magnetic field on the neutral line is large. However, it can be said that clear spatial and temporal correspondences between each individual flare and the distribution of the shear-angle or the current helicity have not been shown yet.

There is an opinion that the reason is that the correlation between the structure of the photospheric magnetic field and the structure of the coronal magnetic field, in which there are reconnection points which directly relate to the flares, is not necessarily high. However, we think that the possibility that some differences of the photospheric magnetic field configurations at the foot-point of the coronal magnetic fields whose states is easy to cause flares and at the other area can be found is high.

The Solar Magnetic Activity Research Telescope (SMART) at the Hida observatory continuously observes the chromosphere in the H alpha absorption line and the photospheric vector magnetogram in the neutral iron absorption line of the full solar-disk, simultaneously. Therefore, by using the SMART, we can investigate the correlation between photospheric magnetic field configurations and locations of flare kernels with various intensities.

At present, we have investigated spatial relationships between flare kernels and some indices of the photospheric vector magnetic field configuration, such as intensity of the current helicity (twist of the magnetic field), distance from the inversion line of the current helicity (borderline of the positive twist and negative twist), gradient strength of the current helicity and distance from the magnetic neutral line etc., mainly for the active region 10808 around Sep.12, 2005.

As a current result, it is shown that brighter flare kernels tend to be generated at nearer places to the inversion line of the current helicity, and that brighter points in the several kernels corresponds to larger values of the current helicity or larger gradients of the helicity, though their values are very small compared with entire active region.

In this paper, we intend to discuss the statistical flare-generating environment, comparing our results with the other recent results such as T.Maeshiro et al. (2005), M.Hahn et al.(2005).

X-class Flares without Coronal Mass Ejections during Solar Cycle 23

S. Yashiro,^{1,2} S. Akiyama,^{1,2} N. Gopalswamy,² and R. A. Howard³

¹*The Catholic University of America, Washington, DC 20064, USA*

²*NASA Goddard Space Flight Center, Greenbelt, MD 20771, USA*

³*Naval Research Laboratory, Washington, DC 20375, USA*

yashiro@ssedmail.gsfc.nasa.gov

We report on 15 X-class flares without coronal mass ejections (CMEs) during solar cycle 23 and their associations with EIT waves, dimmings, and type II radio bursts. There were 122 X-class flares, including five >X10 flares, observed by GOES satellites during 1996 to 2005. We examined their CME associations using the Large Angle and Spectrometric Coronagraph (LASCO) on board the SOHO. Except for the 18 unknown events due to LASCO data gaps, we found that 89 of 104 (or 86%) X-class flares were certainly associated with CMEs, while 15 (or 14%) were not associated with CMEs. Of the 15 X-class flares without CMEs, no events were associated with EIT waves. This confirmed that the result of Cliver et al. (2005) and Chen (2006), who conclude that the EIT waves are associated not with big flares but with CMEs. Two X-class flares without CMEs were associated with metric type II radio bursts. Interestingly, the two flares were also associated with EIT dimmings. These events will be a good example to investigate the metric type II radio burst, whose origin has been a question in controversy either flares or CMEs.

An MHD model for impulsive flares focused on a correlation between plasmoid speed and reconnection rate

Keisuke Nishida¹, Masaki Shimizu¹, Daikou Shiota¹, Hiroyuki Takasaki¹, and Kazunari Shibata¹

¹ *Kwasan and Hida Observatories, Kyoto University, Yamashina, Kyoto 607-8471 Japan*
nishida@kwasan.kyoto-u.ac.jp

Recent space observations have revealed various evidence of magnetic reconnection and common properties in flares (plasmoid ejection, cusp shaped loops, etc.), leading to unified view of various flares (Shibata 1996, 1999). However, the detailed physics of magnetic reconnection has not been established yet. Especially it is not revealed what determines the speed of reconnection, i.e. reconnection rate. Based on many observations, Shibata et al. (1995), Shibata (1999), Shibata and Tanuma (2001) proposed the plasmoid-induced-reconnection model (Figure 1). The fast ejection of the plasmoid can induce the strong inflow into the reconnection site, and then the strong inflow enhances the fast reconnection.

In this study, we performed 2.5-dimensional MHD simulations of solar flares with different resistivity model and different plasmoid velocity, and examined how the reconnection rate depends on the parameters. In higher resistivity case, the reconnection rate becomes larger and consequently plasmoid velocity becomes larger (Figure 2, Series A). In contrast, in the case in which the plasmoid is accelerated by an external force, i.e. in larger plasmoid velocity case, larger inflow is induced by mass conservation, and consequently the reconnection rate also becomes larger (Figure 2, Series B). However the difference of the reconnection rate in Series B is small, because most of the induced inflow flows into Y-shaped slow shock, and the inflow doesn't contribute to the reconnection rate so much. These results are consistent with observations (Ohyama and Shibata 1997, 1998, Shimizu 2006) and support plasmoid-induced-reconnection model.

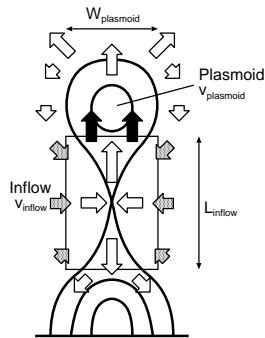

Figure 1: Schematic picture of the the plasmoid-induced-reconnection model. Block arrows show gas flow.

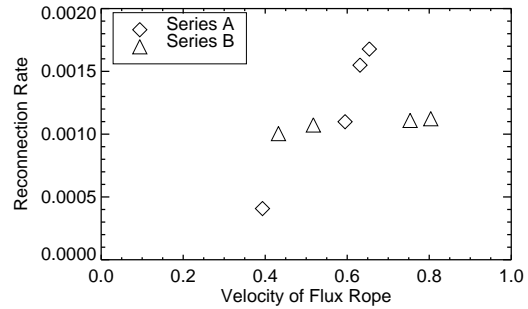

Figure 2: Reconnection rate vs. plasmoid velocity. Diamonds denote the case in which the resistivity is changed (Series A), and triangles denote the case in which the plasmoid is accelerated by an external force (Series B).

References

- [1] Ohyama, M. & Shibata, K. 1997, PASJ, 49, 249
- [2] Ohyama, M. & Shibata, K. 1998, ApJ, 499, 934
- [3] Shibata, K. 1996, Advances in Space Research, 17, 9
- [4] Shibata, K. 1999, in Structure Formation and Function of Gaseous, Biological and Strongly Coupled Plasmas, p. 74, 74+
- [5] Shibata, K., Masuda, S., Shimojo, M., Hara, H., Yokoyama, T., Tsuneta, S., Kosugi, T., & Ogawara, Y. 1995, ApJ, 451, L83+
- [6] Shibata, K. & Tanuma, S. 2001, Earth, Planets, and Space, 53, 473
- [7] Shimizu, M. 2006, Master Thesis, Kyoto University

The relationships among Solar Wind Speed, Coronal Magnetic Field, and Photospheric Magnetic Field

K. Hakamada¹, M. Kojima², K'I Fujiki², and M. Tokumaru²

¹ Department of Natural Science and Mathematics, Chubu University, Aichi, 487-8501 JAPAN,

² Solar-Terrestrial Environment Laboratory, Nagoya University, Aichi, 442-8507 JAPAN

hakamada@solan.chubu.ac.jp

We obtained good relationships among the solar wind speed, V , the radial component of coronal magnetic field, B_{r_sou} , and the radial component of photospheric magnetic field, B_{r_pho} , assuming the following multiple linear regression equation; $V = A + B \times \log_{10} |B_{r_sou}| + C \times \log_{10} |B_{r_pho}|$. V is estimated by Interplanetary scintillation observations and magnetic fields, B_{r_sou} and B_{r_pho} , are calculated by the potential field model for the coronal magnetic field. We use synoptic maps of the photospheric magnetic field observed at the NSO, Kitt Peak, USA, and those of V , estimated by the computer-assisted tomography technique by the STE-Lab, Nagoya University, Japan, for the following thirteen Carrington rotations; CR 1830, CR 1844, CR 1855, CR 1870, CR 1887, CR 1898, CR 1901, CR 1909, CR 1925, CR 1939, CR 1950, CR 1964, and CR 1976. These Carrington rotations cover the entire solar activity cycle from the maximum phase of cycle 22 through the maximum phase of cycle 23. We selected these thirteen Carrington rotations for a good data coverage of V on the synoptic maps. We classified the data into two groups by the magnitude of magnetic field;

(I) group 1: $-1.5 \leq \log_{10} |B_{r_sou}| < 0.0$, and $-1.0 \leq \log_{10} |B_{r_pho}| < 1.5$,

(II) group 2: outside the range of group 1.

We obtained the following results;

(1) The multiple correlation coefficient, R , of group 1 is high, $R = 0.654$, and that of group 2 is low, $R = 0.156$.

(2) The multiple regression equation for group 1; $V = 960.5 + 328.6 \times \log_{10} |B_{r_sou}| - 72.0 \times \log_{10} |B_{r_pho}|$.

(3) The multiple regression equation for group 2; $V = 495.4 + 21.3 \times \log_{10} |B_{r_sou}| - 18.5 \times \log_{10} |B_{r_pho}|$.

These results suggest that the solar wind consists of two groups; the one is the solar wind of group 1 that is accelerated to $450 - 800 \text{ km s}^{-1}$ by a mechanism related to both $\log_{10} |B_{r_sou}|$ and $\log_{10} |B_{r_pho}|$ in the funnel of magnetic tube expanding from regions of weak field in the photosphere and the other is the background solar wind of group 2 that has an average constant speed of 436 km s^{-1} and is independent of both $\log_{10} |B_{r_sou}|$ and $\log_{10} |B_{r_pho}|$.

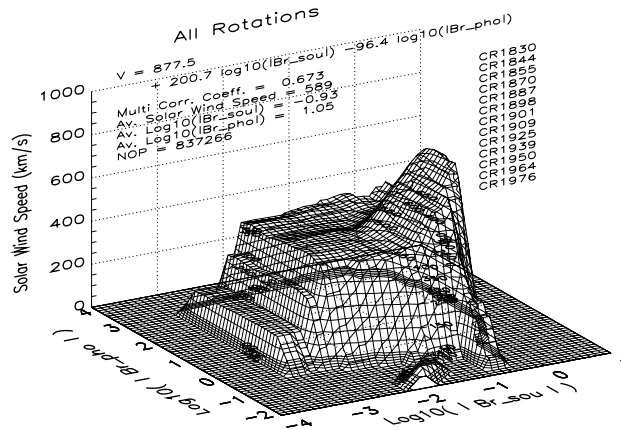

Figure 1: The surface plot of solar wind speed distribution. The axes of $\log_{10} |B_{r_sou}|$ and $\log_{10} |B_{r_pho}|$ are the horizontal plane and the axis of V is perpendicular to the horizontal plane. Two planes are clearly seen in this figure; the wide horizontal plane corresponds to the background solar wind of nearly constant speed, about 436 km s^{-1} on the average, and the plane tilted to the horizontal plane suggests the acceleration of the solar wind.

Processes of the Alfvén wave compression by high-speed solar winds

K. Tsubouchi¹

¹ *Space Environment Group, National Institute of Information and Communications Technology, Koganei, Tokyo, JAPAN*
tsubo@nict.go.jp

Interplanetary magnetic structures associated with nonlinear evolution of Alfvén waves are investigated by means of hybrid simulations. Special attention is paid to the process that high-speed streams (HSS) of the solar wind overtake the waves ahead. Through this process, the Alfvén waves are expected to steepen and evolve into a rotational discontinuity (RD). In the vicinity of such steepened Alfvén waves, a localized weak magnetic field called magnetic decrease (MD) is often found. Since MD dominantly consists of more anisotropic plasmas ($T_{\perp}/T_{\parallel} > 1$) than the surrounding region, it has been considered as remnants of a mirror instability. Recent studies of *Tsurutani et al.* [2005] suggested that anisotropic plasmas are generated due to perpendicular acceleration of protons by a ponderomotive force intensified at the steepened edge of waves. On the other hand, we show more efficient and stable MD formation from 1D hybrid simulation, where interplanetary RDs interact with a super-critical fast shock [*Tsubouchi and Matsumoto, 2005*]. In our model, anisotropic plasmas are already generated by the shock compression, and the imposed rotational field releases such anisotropy more quickly than the normal mirror instability process. The present study modifies this simulation model to verify the effects of gradual compression on the generated MD properties. Particle behaviors during the MD formation is specifically discussed in detail.

Study of reconnection layer structure with density asymmetric current sheet

K. G. Tanaka¹, M. Fujimoto¹, and I. Shinohara¹

¹ ISAS/JAXA

tkentaro@stp.isas.jaxa.jp

Recent Cluster spacecraft observations (Retino et al. 2006) have obtained a detailed structure of a magnetic reconnection separatrix region (SR) on the magnetospheric (MSP) side of the magnetopause (MP). According to those results, a strong electron beam parallel to the magnetic field, a deep density cavity, a strong electric field normal to the MP, and an ion jet away from the X-line are found in the SR. We have carried out two-dimensional full-particle simulations of tearing mode instability with an asymmetric plasma density in order to compare to those observation results. The simulation study has identified the most suitable location for the observations. At that location a sharp density dip, both the ion and the electron flows away from the X-line, a normal electric field component, and a strong electron beam parallel to the magnetic field are found. Then we have observed the structures of the current layer at different locations in the simulation domain. At the SR on the MSP side far from the X-line, both a significantly strong electron beam and a sharp density dip are seen. At the SR on the magnetosheath side near the X-line, an electron beam toward the X-line and a large Hall magnetic field are found.

MHD Study of Three-Dimensional Instability in the Spontaneous Fast Magnetic Reconnection

T.Shimizu, M.Ugai¹ and K.Shibata²

¹ *Dept. of Computer Science, Ehime University, Matsuyama, JAPAN,*

² *Kwasan Observatory, Kyoto University, Kyoto, JAPAN*

shimizu@cs.ehime-u.ac.jp

The basic mechanism of the three-dimensional fast magnetic reconnection is studied by MHD simulations. As well known in previous many MHD studies, two-dimensional fast magnetic reconnection is basically stable. Because, once the reconnection process is built up in the exactly two-dimensional current sheet, the reconnection process can be continued until every magnetic field line to be reconnected vanishes. At the time, the externally driven mechanism to push the current sheet is not necessarily needed. Instead, the ejected magnetic loop (plasmoid) can maintain and promote the reconnection process as a positive feedback. However, in three-dimensional case, plasma can flow in the sheet current direction. In particular, unmagnetized and strong plasma flows along the magnetic neutral line may disturb the reconnection process and sometimes inversely enhance.

In this paper, it is shown that the two-dimensional magnetic reconnection is changed to three-dimensional by a small three-dimensional perturbation in the exactly two-dimensional current sheet. In the MHD model, various types of electric resistivity model are examined. If we put a current-driven type anomalous resistivity, three-dimensional development (instability) of the reconnection process becomes active and drastic. As a result, the ejection of plasmoid becomes intermittent and is strongly localized in the sheet current direction. This MHD simulation result is compared with image data of the intermittently downflowing plasma bulks observed in solar flares.

**Full particle simulation of a perpendicular collisionless shock:
A shock-rest-frame model**

Ryo Yamazaki¹ and Takayuki Umeda²

¹ *Department of Physics, Hiroshima University, JAPAN,*

² *Solar-Terrestrial Environment Laboratory, Nagoya University, JAPAN*

ryo@theo.phys.sci.hiroshima-u.ac.jp

Full kinetic dynamics of a perpendicular collisionless shock is studied by means of a one-dimensional electromagnetic full particle simulation. The present simulation domain is taken in the shock rest frame in contrast to the previous full particle simulations of shocks. Preliminary results show that the downstream state falls into a unique cyclic reformation state for a given set of upstream parameters through the self-consistent kinetic processes.

Visualization and Analysis of Three Dimensional Shock Surfaces formed in MHD Simulation of Magnetic Loop

Y.Fujita¹,K.Kondoh¹ and M.Ugai¹

¹ *Department of Computer Science,Ehime University,Matsuyama,Ehime,Japan*
fujita@msim.cs.ehime-u.ac.jp

We have been studied three dimensional structure of magnetohydrodynamics(MHD) shocks formed in front of magnetic loop. We have studied three dimensional magnetic loop dynamics using MHD simulations on the basis of spontaneous fast reconnection model. In this model, fast reconnection jet ejected from reconnection region collides with magnetic loop. Then, fast shock is formed in front of magnetic loop, and a pair of slow shocks are elongated from reconnection region to magnetic loop. Three dimensional structure of them have been outstanding problem, yet. It is important to understand the three dimensional structure of the shocks.

Shocks are identified from some quantities using Rankine-Hugoniot conditions. These identifications are performed on the each mesh point. Since shock surfaces are curved surfaces, we should smoothly draw the curved surfaces from their points. Then,we use the applied method of metaball. This method is one of the modeling techniques in computer graphics. Metaball is a spheroidal object with a density distribution. We produce density distribution data superposing metaballs located at the points identified as shock surfaces. We use 3D Texture Mapping for the purpose of rendering the shock surfaces from the density distribution data. 3D Texture Mapping is a technique extended 2D Texture Mapping to three dimensions. This technique can render at high speed, and it is easy to simultaneously use with other techniques. Figure 1 shows a sample of slow shocks identified and visualized from the results of three dimensional MHD simulation.

In this paper, we introduce the method to visualize shock surfaces in detail, and clarify the three dimensional structure of them.

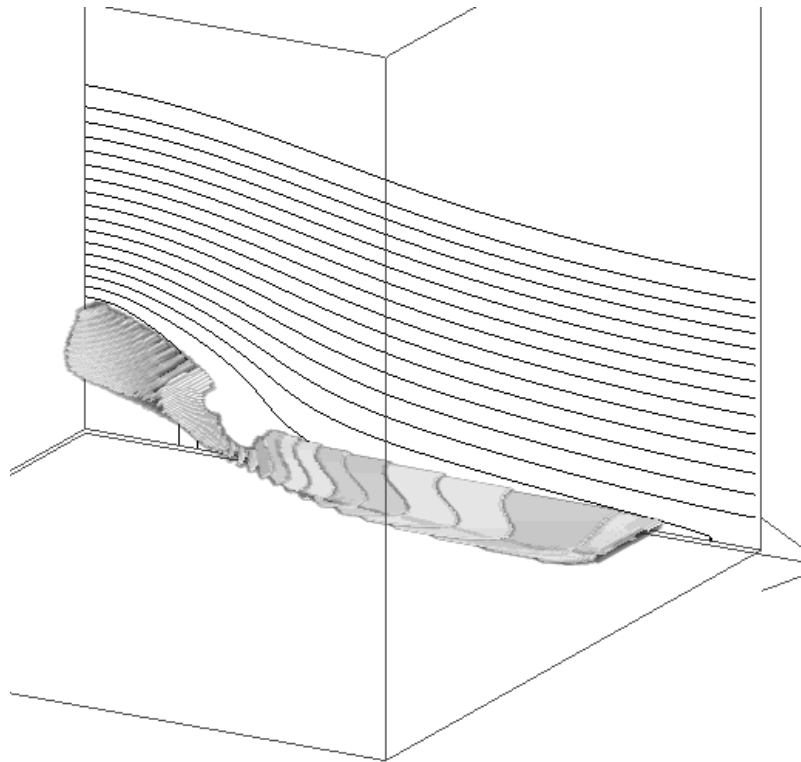

Figure 1: Slow shocks visualized from the results of three dimensional MHD simulation

Electron acoustic dromions in auroral plasma

S. S. Ghosh¹, Y. Omura¹, A. Sen² and G. S. Lakhina³

¹ *Computer Science laboratory, RISH, Kyoto University, Uji, JAPAN,*

² *Institute for Plasma Research, Bhat, Gandhinagar, INDIA,*

³ *Indian Institute of Geomagnetism, New Panvel, Navi Mumbai, INDIA*

sukti@rish.kyoto-u.ac.jp

Present days' in situ measurements with high resolution, space borne instruments have revealed the existence of multidimensional structures in different regions of space. One such example is the observation of monopolar and bipolar pulses in the auroral region by POLAR and FAST satellites. Dromions, which are exponentially localized structures in two dimensions, are proposed a possible model for such multidimensional waves. It has been shown that the nonlinear evolution of a two dimensional electron acoustic wave are governed by Davey-Stewartson - I (DS-I) equations which may lead to dromion solutions. The time evolution of the dromion solution and its stability has been studied in the context of auroral plasmas. The effect of different parameters on the shape and size of the dromion solutions has also been estimated. The analytical study has been extended to fluid simulations in two dimensions with time dependent boundary conditions. The numerical results are compared with the previous analytical estimations.

Study of plasma environment at geosynchronous orbit of the real-time magnetosphere simulation for spacecraft charging forecast as space weather services

M. S. Nakamura^{1,4}, H. Shimazu^{1,2,4}, T. Obara^{1,4}, S. Fujita^{3,4}, and T. Tanaka^{2,4}

¹ *National Institute of Information and Communications Technology, Koganei, Tokyo, JAPAN,*

² *Department of Earth and Planetary Sciences, Kyushu University, Fukuoka, JAPAN,*

³ *Meteorological College, Kashiwa, Chiba, JAPAN*

⁴ *CREST, JST, JAPAN*

nakamura.masao@nict.go.jp

Plasma environment at the geosynchronous orbit is closely related to geosynchronous spacecraft surface charging, that would cause spacecraft anomalies with resulting electrostatic discharging. Intense fluxes of hot electrons with energy in the range of several to several tens of keV during substorm activities are mainly responsible for spacecraft surface charging. For spacecraft charging forecast as space weather services, it is important to predict the variation of the plasma environment at the geosynchronous orbit. A real-time three-dimensional magneto hydrodynamic (MHD) magnetosphere simulation of solar wind-magnetosphere-ionosphere coupling system, using the real-time solar wind data from the ACE spacecraft every minute as the upstream boundary conditions for density, temperature, flow speed, and magnetic field, has started at the National Institute of Information and Communications Technology (NICT). It can reproduce the global response of the magnetosphere and ionosphere. The plasma environment at the geosynchronous orbit and AE indices are also calculated in the simulation. We compare the simulated plasma environment to the LANL geosynchronous satellites observations. It shows that the simulation can capture a lot of substorm injections. However the simulated plasma pressure tends to be substantially smaller than the observed ion pressure, maybe due to the limitation of the MHD code, i.e. the lack of kinetic heating processes. On the other hand, the simulated plasma pressure shows meaningful quantitative correlation with the observed electron pressure during substorm activities, although its temperature and number density themselves do not always show the good correlation with the observations. We will discuss features of variation of the plasma environment during substorm activities and the possibility of spacecraft surface charging forecast at the geosynchronous orbit using the real-time MHD magnetosphere simulation.

Fokker-Planck modeling of the non-thermal electrons in a solar flare. -numerical simulation and comparison with the observations-

T. Minoshima and T. Yokoyama¹

¹ *Department of Earth and Planetary Science, University of Tokyo, Tokyo, Japan.*
takashim@eps.s.u-tokyo.ac.jp

To study the dynamics of solar flares is critically important for understanding the Sun-Earth system and predicting space weather. It has been reported that the plasmoid ejections and the hard X-ray (HXR) emissions associated with the impulsive solar flare are temporally correlated (Takasaki 2006). So the study of flare high energy (non-thermal) phenomena is also one of the keys for the whole understanding of the Sun-Earth system.

Characteristics of high energy (non-thermal) electrons in solar flares can be discussed from the HXR and/or optically thin radio observations. HXRs are thought to be emitted from electrons with energy below several hundred keV, whereas radios are thought to be emitted from electrons with energy above several hundred keV. So the comparative analysis using the HXR and radio observations is useful for discussing the flare non-thermal electrons over a wide range of energies. There have been reported that the non-thermal electron spectra inferred from the HXR and radio spectra are significantly different (e.g., Silva et al. 2000), that is, the electron spectrum inferred from the radio spectrum is often quite harder than that inferred from the HXR spectrum. To explain this feature of electron spectra inferred from the HXR and radio spectra, two models have been proposed, namely, the second-step-acceleration (e.g., Bai & Ramaty 1976), and the trap-plus-precipitation (e.g., Melrose & Brown 1976).

Here we present the comparative spectral analysis of the 29 May 2003 X1.2 flare using the RHESSI and Nobeyama observations. We fit the temporally-resolved non-thermal spectra of HXR (50 - 200 keV) and radio (17 - 35 GHz) by a double power-law and a single power-law function. Then we obtain three spectral indices of lower-energy HXR, higher-energy HXR, and radio as a function of time. We compare them and find the following features of spectra and their evolution: (1) The spectrum of radio is quite harder than those of HXR. (2) There are time delays in the time profiles of them toward the higher energy. The time profile of the spectral index of higher-energy HXR lags that of lower-energy HXR (which shows the so-called *soft-hard-soft* behavior), and the time profile of the spectral index of radio lags that of higher-energy HXR.

These observational features are expected to give us key informations on the dynamics of the non-thermal electrons in a solar flare. We try to interpret these features in terms of the electron transport of the trap-plus-precipitation model. The Fokker-Planck modeling is one of the useful method to examine the temporal evolution of electrons. So we first numerically solve the gyro-averaged, spatially-homogeneous Fokker-Planck equation (e.g., Leach & Petrosian 1981; Lu & Petrosian 1988; Hamilton et al. 1990) with the additional term of precipitation flux. The spectral evolutions of the calculated electrons and the predicted non-thermal emissions (assuming the emission models of HXR and radio) are analyzed and compared with the observation. Then we discuss the probable mechanism of the non-thermal electron transport in a solar flare based on both the observation and calculation.

In addition to these studies, we now try to solve the gyro-averaged Fokker-Planck equation with taking the spatial variation into consideration. We are going to present the results of this calculation.

Relation of the aurora activity with the magnetospheric dynamics in the rapid rotational planets

K. Fukazawa¹, T. Ogino¹ and R. J. Walker²

¹ *Solar Terrestrial Environment Laboratory, Nagoya University, Nagoya, Aichi, JAPAN,*

² *Institute of Geophysics and Planetary Physics, and Department of Earth and Space Science, University of California, Los Angeles, USA*

fukazawa@stelab.nagoya-u.ac.jp

It is clear that the aurora plays an important role to understand the dynamics of magnetosphere from the last observations of Earth's magnetosphere. However, we have not almost recognized the relation of the aurora and magnetospheric dynamics yet. Then to deepen our understanding to this relationship, we examine how that relation is on the rapid rotation planetary magnetosphere like Jupiter and Saturn with a computer simulation. We chose the simulation parameters for Jupiter's and Saturn's conditions to be compared with the observations. First, to know the basic response, we used the fixed solar wind dynamic pressure and changed IMF conditions (y and z components). As the results the dawn-dusk asymmetry appeared due to the rotation for both cases. In particular for Jupiter case when the IMF was northward, the magnetospheric convection was sharply bended around dawn side. This is caused by the tension of the magnetic field line owing to the interaction of the solar wind and corotation plasma. Then we examined how the rapid rotation affects the aurora activity when the shock wave passed the magnetosphere. From this result when the shock wave passed, the corotation plasma interacted with the solar wind and that interaction often made a large vortex around dusk side in the magnetosphere. Then we mapped this to the polar of planet, the upward field-aligned current on that vortex region increased. This is a reason why that shock wave passing affects the spot aurora. In this presentation we show the results of these simulations and discuss that dynamics.

New MHD simulation codes with a higher-order non-oscillatory scheme

S. Tanaka¹, T. Umeda¹, T. Ogino¹, Y. Matsumoto¹

¹ *Solar-Terrestrial Environment Laboratory, Nagoya university, Nagoya, JAPAN*
stanaka@stelab.nagoya-u.ac.jp

We developed a new one-dimensional MHD simulation code with the Polynomial Interpolation for hyperbolic Conservation laws (PIC) scheme. There are a number of numerical methods to avoid numerical instability and diffusion when solving hydrodynamic equations. Cubic Interpolated Profile (CIP) method was developed to solve advection equations with high accuracy. When applying the CIP method to hydrodynamic equations, it is necessary to add a certain artificial viscosity to avoid numerical oscillations at discontinuities. TVD schemes can avoid numerical oscillations without artificial viscosity. However, these schemes are not appropriate for profiles with local maximum or minimum. To cope with above problems, we apply PIC scheme to ideal MHD equations in conservative forms. We perform test simulations to compare our scheme with several numerical schemes.

Three-dimensional full-particle simulations of ion beam instability

T. Miyake¹, M. Okada², H. Usui³, T. Ishikawa¹, D. Matsuoka⁴, T. Murata⁴, Y. Omura³

¹ Toyama Prefectural University, Imizu, Toyama, JAPAN,

² National Institute of Polar Research, ROIS, Itabashi, Tokyo, JAPAN,

³ Research Institute for Sustainable Humanosphere, Kyoto University, Uji, Kyoto, JAPAN,

⁴ Center for Information Technology, Ehime university, Matsuyama, Ehime, JAPAN

miyake@pu-toyama.ac.jp

In efficient exploration and utilization of the geospace environment, it is very important to understand interactions between spacecraft and electromagnetic environment around themselves. Recently, influences of spacecraft on space electromagnetic environment are gradually increasing due to new space technologies such as ion engine which is used in HAYABUSA satellite, as schematically illustrated in Fig.1. When the ion engine emit a large quantity of accelerated heavy ions to the space, these heavy ion beams interact with space plasmas around the spacecraft, which can excite some kind of beam instabilities and plasma waves. This kind of beam instabilities and plasma waves become serious noises in observing electromagnetic environment in space by satellites.

We investigate about time evolutions of ion beam instabilities excited by ion beams emitted from ion engine, as a case study of the influences on space environment by spacecraft. We perform three-dimensional computer experiments of ion beam instabilities, and demonstrate nonlinear evolutions of ion beam instabilities, in time as well as in space, as presented in Fig.2. Simulation study of beam instabilities are difficult because these instabilities are very sensitive to numerical thermal noises in full-particle simulations. We developed, therefore, three-dimensional particle simulation code which is specialized to parallel computing on large scale super computers, especially Earth Simulator. In the present study, we perform three-dimensional particle simulations of the most fundamental beam instabilities excited by a spatially uniform beam at first. Next, we perform simulations of localized beam instabilities excited by a spatially localized ion beam, and investigate on the interaction between ion beam and space electromagnetic environment. Especially, we focus on the spatial characteristics on the perpendicular plane against the ambient magnetic field.

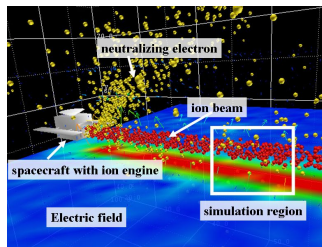

Figure 1: A schematic illustration of simulation model.

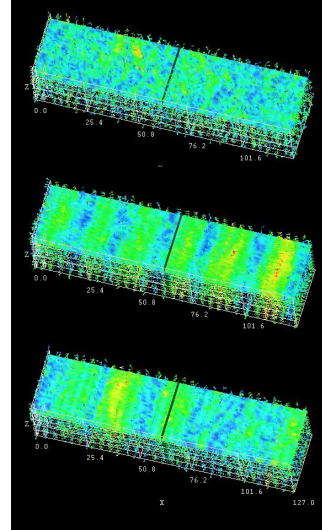

Figure 2: A nonlinear evolution of electric fields of ion beam instability.

Solar-Terrestrial data Analysis and Reference System Based on Web Service and RSS1.0

Ken T. Murata¹, Satoshi ISHIKURA², Takuya KUBO², Kazunori Yamamoto², and Eizen KIMURA³

¹ Center for Information Technology, Ehime University, Matsuyama, Ehime, JAPAN,

² CGraduate School of Science and Engineering, Ehime University, Matsuyama, Ehime, JAPAN,

³ Department of Medical Informatics Social Medicine and Medical Informatics Medical School of Ehime University, Matsuyama, Ehime, JAPAN

murata@cite.ehime-u.ac.jp

Overview: In the geo-science and the STP (Solar-Terrestrial Physics) fields, various observations have been done by satellites and ground-based observatories. These data are managed in multiple organizations, and types of procedures and rules to provide the data are independent from each other. Researchers have felt difficulty in searching and analyzing such different types of data together. To support cross-over analyses of these data, we have developed the STARS (Solar-Terrestrial data Analysis and Reference System). The meta-database of the STARS includes directory information, access permission information, protocol information, hierarchy information of mission, team and data and user information. We call this meta-database as the STARS-DB. Users of the STARS are able to download without knowing location of data files by making use of the STARS-DB.

Searching and Downloading observation data: The STARS5 application searches and downloads observation data by using the Web services. When a user starts searching observation data, The STARS5 accesses the portal Web service (Portal-WS) by sending a SOAP request. Then it receives meta-data as a SOAP response. When desired data files are found, a user can download the data files. Download of the data files are done by accessing the download agent Web service (DLAgent-WS). The DLAgent-WS downloads the data files from an adequate organization with an adequate protocol. At present, supported protocols are FTP, SFTP, FTPS, HTTP, HTTPS. The DLAgent-WS used to adopt the SwA (SOAP message with Attachment), but it did not show a good performance. Now, the DLAgent-WS uses the DIME/WS-attachment. Note both protocol satisfies the SOAP 1.1 regulation.

Collecting meta-data of observatin data: We developed an automatic meta-data collection system for the observation data using the STARS-RSS (RDF Site Summary) 1.0. The RSS 1.0 is one of the XML-based markup languages based on the RDF (Resource Description Framework), which is designed for syndicating news and content of news-like sites. Using the RSS1.0 as a meta-data distribution method, the workflow from retrieving meta-data to registering them into the database is automated. This technique was applied for the DARTS (Data Archive and Transmission System), which is a science database managed by the PLAIN Center at ISAS/JAXA in Japan. We succeeded in generating and collecting the meta-data automatically.

Future works: Our future plan is to construct the STARS Semantic Web. The Semantic Web provides a common framework that allows data to be shared and reused across applications, enterprises, and communities. The Semantic Web has a strong relation among each information web because the meta-data expressed in the RDF (Resource Description Framework) which is machine-readable information. The RDF describes meta data in three elements (the subject, the predicate, and the object). The database can be used effective by using the Semantic Web, and an interdisciplinary retrieval becomes possible.

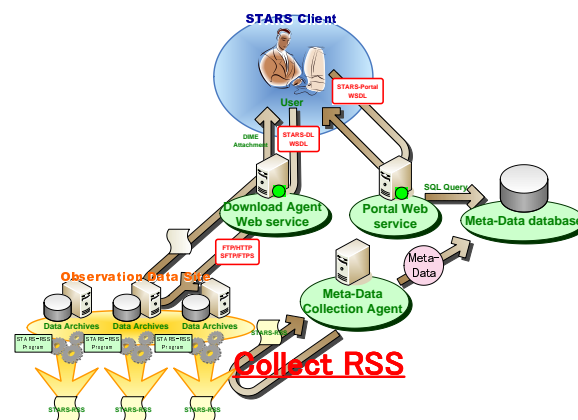

Figure 1: Whole processes to collect meta-data from data sites..

Poster Session II

Short Oral Presentation
(November 16 : 15:40 – 16:10)

Core Presentation Time
(November 16 : 16:10 – 17:40)

Calibration of the X-Ray Telescope on Solar-B

L. Lundquist¹, J. Cirtain¹, M. Weber¹, P. Jibben¹, K. Reeves¹, and the XRT Team

¹ *Harvard-Smithsonian Center for Astrophysics, Cambridge, Massachusetts, USA*

llundquist@cfa.harvard.edu

The X-Ray Telescope (XRT), recently launched on the Solar-B mission, combines high sensitivity and broad dynamic range for unprecedented spatial and temporal resolution in solar coronal observations. The XRT team has performed numerous calibration studies, both pre- and post-launch, to characterize and fine-tune instrument performance. These studies include characterization of the dark current, with thermal and read-out noise of the CCD; determination of best focus position and point spread function; and quantification of the total telescope throughput, including filter transmission and effective area. We discuss the results of these calibrations and present analysis of their implications for scientific research.

The measurement of ascent speed of the ephemeral active regions using the cloud model

Kenichi. Otsuji¹ and Reizaburo. Kitai²

¹ Department of Astronomy, Kyoto university, Kyoto, JAPAN

² Kwasan and Hida observatories, Kyoto university, Kyoto, JAPAN

otsuji@kwasan.kyoto-u.ac.jp

Ephemeral active regions (ERs) are small and short-lived regions that emerge in large numbers on the solar surface. In this study, we measure the ascent speed of ERs, by using Beckers' cloud model.

We observe these ERs by Solar Magnetic Activity Research Telescope (SMART) at the Hida observatory with the wavelengths of H α center, ± 0.5 and ± 0.8 Å. The SMART can observe the whole of the sun by high spatial resolution, so we obtain a lot of data of ERs emerging on the solar surface (figure 1).

We calculate the contrasts at each point in each wavelength data from the equation as

$$C(\Delta\lambda) \equiv \frac{I(\Delta\lambda) - I_0(\Delta\lambda)}{I_0(\Delta\lambda)}, \quad (1)$$

where $I(\Delta\lambda)$ is the intensity of the ER and I_0 is the intensity of the quiet background. Both intensity are normalized by the intensity of continuum of disk center.

We apply these sets of contrasts to the cloud model and obtain four parameters; source function, optical depth at the absorption line center, Doppler width and Doppler shift. From this way we can get Doppler velocity map of the entire area of the ER (figure 2). Then we investigate the time evolutions of the ascent speed at the loop top and the downward flow at the loop footpoint (figure 3).

From this study we can say two points about ERs.

1. The maximum ascent speed of ERs is about 10km/s and smaller than that of usual Emerging flux regions.
2. The ascent duration time of ERs range from 20 minutes to 1 hour.

For detailed analysis, we intend to observe more ERs and make a statistical survey.

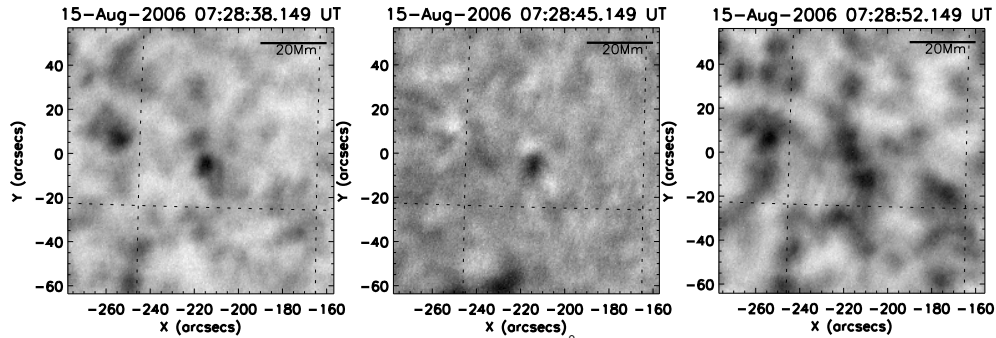

Figure 1: An ephemeral active region. Left: H α - 0.5 Å. Middle: H α center. Right: H α + 0.5 Å.

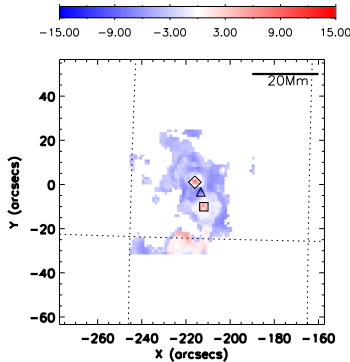

Figure 2: Doppler velocity of the ephemeral active region.

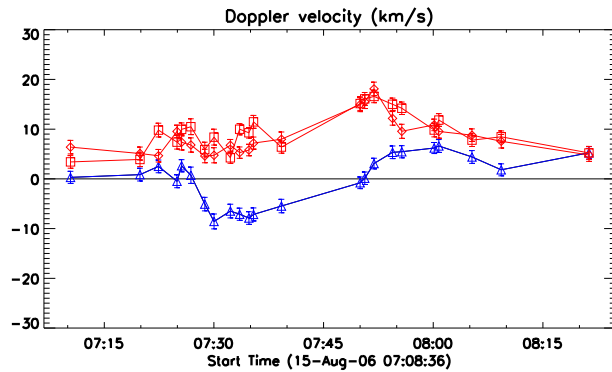

Figure 3: The time evolutions of Doppler velocity. \triangle : Loop top. \diamond : Loop footpoint. \square : Loop footpoint.

Nanoflare and Alfvén wave heating models, predicting differences in the observational signatures

P. Antolin¹, K. Shibata², D. Shiota³ & D. Brooks⁴

¹ *Department of Astronomy, Graduate School of Science, Kyoto University, Kyoto, JAPAN,*

² *Kwasan and Hida Observatories, Kyoto University, Kyoto, JAPAN,*

³ *Earth Simulator Center, JAMSTEC, Yokohama, Kanagawa, JAPAN,*

⁴ *Naval Research Laboratory, Washington DC, USA*

antolin@kwasan.kyoto-u.ac.jp

Among the most puzzling unsolved astrophysical phenomena, stands the coronal heating problem which consists in identifying and understanding the physical mechanism responsible for the few million degree coronal temperatures. The solution involves many steps starting from identifying an energy source, to predicting observable quantities as the spectrum of emitted radiation. Promising coronal heating mechanisms are the Alfvén wave heating mechanism in which Alfvén waves transport the energy into the corona (Alfvén 1947; Narain & Ulmschneider 1996), and the Nanoflare heating mechanism, in which the energy is released through many small reconnection events (Parker 1988; Priest et al. 2002). This work offers a comparison between these two heating mechanisms in the case of a coronal loop using 1.5-D MHD numerical simulations with the CIP-MOCCT scheme (Yabe & Aoki 1991; Evans & Hawley 1988). Following previous works (Moriyasu et al. 2004) in which the Alfvén wave heating model of the loop is presented, we investigate the hydrodynamic response of a loop heated by nanoflares. We also consider the case of a loop being heated by both Alfvén waves and nanoflares. The observational consequences of each model are investigated predicting the XRT intensity fluxes for Solar-B in order to distinguish the different observable signatures of these two heating mechanisms.

Comparison between Characteristics of Filament Eruptions and Magnetic Flux Ropes

Y. Yamauchi¹, T. Magara², K. Marubashi³, M. Oka², K. Otsuji², K. Nagashima², and K. Shibata²

¹ *Hida Observatory, Kyoto University, Takayama, Gifu, JAPAN,*

² *Kwasan Observatory, Kyoto University, Kyoto, Kyoto, JAPAN,*

³ *660-73, Mizuno, Sayama, Saitama, JAPAN*

yamauchi@kwasan.kyoto-u.ac.jp

Understanding the relation between solar activities and disturbances of the plasmas and magnetic field in the interplanetary is essential for the study of space weather. Many researchers have tried to reveal the relation (e.g., Marubashi, 1986; Watari et al., 2001). However, it has not been fully understood yet, because it is still unknown how a disturbance generated on the Sun propagates to the earth through the interplanetary space due to the lack of information between the Sun and the earth. We study the relation between filament eruptions and magnetic flux ropes using H α images taken at Hida Observatory, Kyoto University and solar wind plasma and magnetic field data by ACE spacecraft. SOHO/LASCO images are also used to check whether coronal mass ejection (CME) is formed in association with the corresponding filament eruption observed in H α . Eight magnetic flux ropes are found from ACE data in April to December, 2005. We derive the parameters of the flux ropes, such as axis direction, strength of magnetic field, radius, and helicity by the fitting of a cylindrical model (Goldstein 1983; Marubashi, 1986). In the meeting, we report the results of the analysis and discuss how disturbances generated at the solar surface propagate in the interplanetary space comparing between the parameters of magnetic flux ropes and the corresponding filament eruption events.

References

- Goldstein, H., 1983, Solar Wind Five (ed., M. Neugebauer), NASA Conf. Publ., CP-2280, 731.
Marubashi, K., 1986, Adv. Space Res., 6, 335.
Watari, S., T. Watanabe, and K. Marubashi, 2001, Sol. Phys., 202, 363.

Current concentrations above active regions before flare eruptions and CME releases

J. C. Santos and J. Büchner

Max-Planck Institute for Solar System Research, Katlenburg-Lindau, GERMANY

santos@mps.mpg.de

Both solar flare eruptions and the release of coronal mass ejections (CMEs) are closely related to magnetic reconnection. Since reconnection is possible only through non-ideal plasma regions, where the frozen-in condition for magnetic fields is violated, current sheets have to be formed before reconnection can take place.

We were looking for the sites, where current sheets were formed before the eruption flare and CME eruption from NOAA AR 8210 on May 1, 1998. Starting with the observed photospheric magnetic field in and around the active region and imposing a photospheric plasma motion we obtain both the parallel (force-free) and perpendicular electric currents, generated in the corona above the active region. We compare the simulated locations of current concentrations in the corona with the sites of the primary flare explosion and of the CME release. We also test predictions of potential current sheets locations based on geometrical methods applied to the extrapolated from the photospheric measurements potential magnetic fields.

Determining the photospheric plasma flow from photospheric magnetic field measurements

J. C. Santos¹ and J. Buchner¹

¹ *Max-Planck Institute for Solar System Research, MPS, Katlenburg-Lindau, GERMANY*
santos@mps.mpg.de

In this work we test three different methods of obtaining the photospheric plasma flow from magnetic field measurements. We apply the methods to simulation data output where the imposed velocity field is known. We compare the output of the methods with the imposed velocity field by means of two measures. The first measure compares the local direction of the vector fields and the second measure the local modulus. The final goal is to determine which methods produce results that are suitable to be used as a boundary condition to our 3D MHD numerical simulation.

MHD simulations of solar emerging flux regions using the Earth Simulator

H. Isobe¹, T. Miyagoshi², K. Shibata³, and T. Yokoyama⁴

¹ *Department of Earth and Planetary Science, University of Tokyo, Bunkyo-ku, Tokyo, JAPAN,*

² *ISAS/JAXA, Sagami-hara, Kanagawa, JAPAN,*

³ *Kwasan and Hida Observatories, Kyoto University, Yamashina, Kyoto, JAPAN*

isobe@eps.s.u-tokyo.ac.jp

Emerging flux regions are where magnetic flux generated in the interior of the Sun emerges through the photosphere into the atmosphere. They are believed to play important role in both energy accumulation and trigger of solar flares and coronal mass ejections. In this paper we present the results of three-dimensional magnetohydrodynamic simulation of an emerging flux region performed on the Earth Simulator. Owing to the high resolution simulation achieved by the Earth Simulator we could investigate the formation of fine structure and the global evolution of emerging flux at the same time. We found that (1) formation of dense filament and small scale current sheets in the emerging flux due to the magnetic Rayleigh-Taylor instability, and (2) intermittent, patchy magnetic occurs between the emerging flux and pre-existing magnetic field in the solar corona. They naturally explain many observed features of emerging flux regions such as formation of arch filament system and intermittent coronal heating.

Three-Dimensional Flux Tube Dynamics in the Solar Corona

S. Inoue¹ and K. Kusano²

¹ *Solar-Terrestrial Environment Laboratory, Nagoya University, Furo-cho, Chikusa-ku, Nagoya, 464-8601, JAPAN,*

² *The Earth Simulator Center, JAMSTEC, 3173-25, Showa-machi, Kanazawa-ku, Yokohama, 236-0001, Japan*

inosato@stelab.nagoya-u.ac.jp

The solar filament eruption is a very important process for the formation of Coronal Mass Ejections. The trigger mechanism, however, is not yet clearly understood. Priest & Forbes (1990) proposed a filament eruption model based on the loss-of-equilibrium theory. This model is that the flux tube embedded in a magnetic arcade may erupt as a consequence of that the equilibrium configuration is broken due to change the photospheric boundary condition. However, this model was constructed in a two dimensional space and did not consider the three dimensional dynamics. In this paper, we carried out the linear analysis of the three-dimensional stability of the flux tube equilibrium proposed by Priest & Forbes, and also performed the three-dimensional nonlinear simulation of that.

As a result, we found that the flux tube proposed by Priest & Forbes is unstable to kink mode when the system approaches to the loss-of-equilibrium state. Our simulation shows that, when the flux tube is long enough, it can ascend continuously as a consequence of growing the kink instability. On other hand, the short flux tube stops at certain height, though the kink instability grows up in initial phase. It implies that the chain process from the loss-of-stability to the loss-of-equilibrium should be important to develop ejective eruptions based on the simulation results. Furthermore, we are going to report the results of simulation study on the role of magnetic reconnection in magnetic flux erupting.

The Extrapolation of Three-Dimensional Magnetic Field in the Solar Corona

S. Inoue,¹ K. Kusano,² and T. Miyagoshi³

¹ *Solar-Terrestrial Environment Laboratory, Nagoya University, Furo-cho, Chikusa-ku, Nagoya, 464-8601, JAPAN,*

² *The Earth Simulator Center, JAMSTEC, 3173-25, Showa-machi, Kanazawa-ku, Yokohama, 236-0001, JAPAN,*

³ *JAXA/ISAS, 3-1-1, Yoshinodai, Sagami-hara, Kanagawa, 229-8510, JAPAN*

inosato@stelab.nagoya-u.ac.jp

It has been widely accepted that the coronal magnetic field can be approximated by force-free field, because plasma β value is very low ($10^{-1} \sim 10^{-2}$) in the solar corona. However, since the force-free equation is nonlinear, it is not straightforward to solve the coronal magnetic field as a boundary-value-problem using magnetogram observation at the photospheric surface. Although several methods have been developed to extrapolate the coronal magnetic field so far, the routine, which enables the reliable construction of three-dimensional magnetic field in the corona from vector magnetogram, is not yet established. The difficulties in pursuing the extrapolation might be attributed to the fact that vector magnetogram data is not always consistent with the force-free field. There are two possible reasons for it:

1. The resolution of observed data may not be high enough to capture the small scale structure in the nonlinear force-free field.
2. The inherent deviation from force-free field may be substantial, since the plasma β on the photospheric surface is not negligibly small unlike in the coronal region.

The objective of this paper is to develop a new methodology for the modeling of the coronal magnetic field, which may overcome the difficulties above. In order to do it, first, we quantitatively examine the reliability and the feasibility of the conventional magnetofrictional method based on the semi-analytical non-linear force-free field introduced by Low & Lou (1990), and on the results of three-dimensional nonlinear magnetohydrodynamic simulation of flux emerging process. As a result, we confirmed that the magnetofrictional method can construct the precise solution of nonlinear force free field, if the boundary condition is well consistent with the force-free field. However, in the case that the boundary condition is given by a slice data of the three dimensional dynamic simulation, in which the transition layer is included, the convergence into equilibrium is so quickly saturated that a reliable force-free field can not be obtained. It implies the limitation of the nonlinear force-free field model in the practical application. In order to conquer the limitation, second, we will propose a new algorithm for the non-force-free field solver, which is able to construct the general MHD equilibrium including the plasma pressure and the gravity, using the line integral method along magnetic field line from the photospheric surface.

The process of the flux-rope formation and eruption triggered by the emerging flux

S. Notoya¹ and T. Yokoyama¹ and H. Isobe¹ and K. Kusano² and T. Miyagoshi^{3b}

¹ *Department of Earth and Planetary Science, University of Tokyo, Bunkyo-ku, Tokyo, JAPAN,*

² *Space Simulator Center, JAMSTEC, Yokohama, Kanagawa, JAPAN,*

³ *Japan Aerospace Exploration Agency, Sagami-hara, Kanagawa, JAPAN*

notoya@eps.s.u-tokyo.ac.jp

Emerging flux was thought to be the main trigger of solar flares and perhaps also CMEs. And some important observations showed that the apparent correlation between emerging flux and eruptions of quiescent filaments (Feynman & Martin, 1995; Wang & Sheeley, 1999), which can be observed as CMEs. From these observational studies, Chen and Shibata (2000) performed two-dimensional simulations including the flux rope, which show the eruption process. Their results suggest that the reconnection is a key process for the eruption. But the principle limitation of the flux-rope model is that the ends of the flux-rope are not anchored in the photosphere, and furthermore, the flux-rope is given at the initial condition, and its origin has not been discussed so much. So our purpose in this paper is to investigate that how such a flux-rope is produced and how an eruption process can be initiated by the emerging flux and what effects of three-dimensionality appear in the process of eruption. For that purpose, we performed three-dimensional numerical simulations of the emerging flux model by solving the resistive compressible MHD equations. From our results, a flux-rope is produced from the coronal arcade field by the reconnection process, and when the reconnection process proceeds effectively, the produced structure is ejected upward by the magnetic force.

High speed solar wind and coronal holes near solar minimum

S. Watari¹

¹ *Space Environment Group, National Institute of Information and Communications Technology, Koganei, Tokyo, JAPAN*
watari@nict.go.jp

According to the previous studies, solar wind speed observed near 1 AU has a good correlation with size of coronal holes. However, high speed solar winds associated with small coronal holes observed by the SOHO/EIT were observed near solar minimum. Such examples are reported here.

CORONAL MASS EJECTIONS OF 28 OCTOBER 2003 & 14 NOVEMBER 2003 AND ASSOCIATED SPACE WEATHER EFFECTS

Ajaysinh K. Jadeja¹, K.N.Iyer¹, Hari Om Vats² and P.K.Manoharan³.

¹ *Department of Physics, Saurashtra University, Rajkot 360005, India.*

² *Physical Research Laboratory, Navrangpura, Ahmedabad 380009, India.*

³ *Radio Astronomy Centre, Tata Institute of Fundamental Research, Ooty, India.*

ak_jadeja@yahoo.com

The effects of Halo Coronal Mass Ejections (CMEs) erupted on 28 October 2003 and 14 November 2003 are studied and reported here. The signatures of these events in the interplanetary medium (IPM) sensed by Ooty Radio Telescope, the solar observations by LASCO Coronagraph onboard SOHO, GOES x-ray measurements, satellite measurements of the interplanetary parameters, GPS based ionospheric measurements, the geomagnetic storm parameter Dst and ground based ionosonde data are used in the study to understand the space weather effects in the different regions of the solar-terrestrial environment. The effects of these events are compared and possible explanations attempted.

Keywords: CME Coronal Mass Ejection, IPM Interplanetary Medium, GPS-Global Positioning System

The current wedge in Magnetohydrodynamics simulation of fast reconnection model

A. Nakata¹, M. Ugai¹ and K. Kondo¹

¹ Ehime University, Matsuyama, Ehime, JAPAN
nakata@msim.cs.ehime-u.ac.jp

The underlying physical mechanism of magnetospheric current wedge evolution is studied by three-dimensional magnetohydrodynamic simulations on the basis of the spontaneous fast reconnection model. It is demonstrated that when a three-dimensional magnetic loop top is compressed by the fast reconnection jet, field-aligned currents are suddenly generated by the resulting sheared fields inside the loop; simultaneously, a large-scale current-wedge evolves to link, the sheet current ahead of the magnetic loop to the current in the local loop footpoint of reconnected field lines.

Figure 1 shows the magnetic field lines in the X-Y plane and the current flow lines, which are defined as the lines drawn in the direction of current density vector at each spatial point. At $t=42$, when the three-dimensional magnetic loop is fully set up, the current flow lines, directed in the negative z direction, suddenly turn their directions to be concentrated to the local loop footpoint of reconnected field lines. Apparently, the resulting current structure is consistent with the well-known current-wedge.

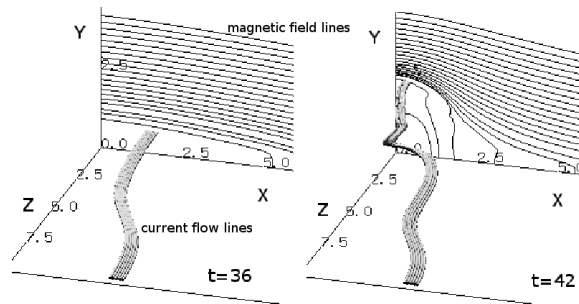

Figure 1: Current flow lines at times $t=36$ and 42 , and magnetic field lines in the X-Y plane

Study of Fast Convection Flow by Three Dimensional MHD Simulations

K. Kondoh¹ and M. Ugai¹

¹ Department of Computer Science, Ehime University, Matsuyama, Ehime, JAPAN

kondo@cs.ehime-u.ac.jp

A lot of magnetohydrodynamic (MHD) simulations have been done in order to study the magnetic reconnection and the associated phenomena. Magnetic reconnection has been recognized to play a crucial role in catastrophic events in space plasma. We have been indicated that spontaneous fast reconnection model can simulate drastic magnetic reconnection. In geomagnetotail, fast convection flow in the plasma sheet is considered to be one of the manifestations of near-Earth reconnection. Because of its plausible association with near-Earth reconnection, these fast convection flows have been studied in terms of substorm initiation.

In this study, we examine the three dimensional structure of the fast convection flow in the plasma sheet using MHD simulations on the basis of spontaneous fast reconnection model. Our previous study have shown that the fast reconnection evolution involving a pair of standing slow shocks accompanies with the fast convection flow and drastic magnetic field dipolarization. Figure 1 shows the magnetic field lines on $z = 0$ plane and contour lines of x component of flow velocity V_x on $y = 0$ plane at different times, $t=36, 39, 42$. At $t \sim 36$, when the plasmoid has just arrived at the left wall boundary, large magnetic loop forms. Then it grows as magnetic reconnection evolves. All the time shown in Figure 1, fast convection flow is observed only in very restricted narrow channel.

In this paper, we compare our simulation results with the in-situ observations in the geomagnetotail. Our simulation results agree with the satellite observation results even in fine structure. Then, we explain three dimensional structure observed by in-situ satellite using the result of three dimensional simulations in detail.

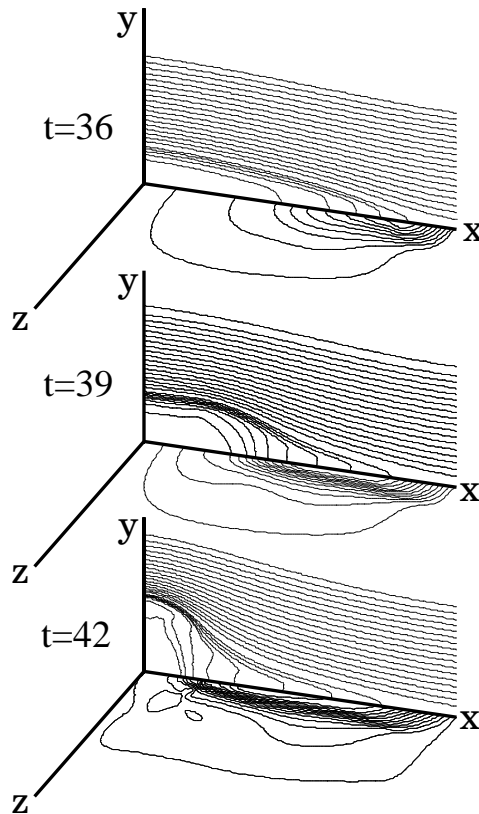

Figure 1: Magnetic field lines on $z = 0$ plane and contour lines of x component of flow velocity V_x on $y = 0$ plane at different times.

Turbulent transport of cold and dense solar wind plasma into the magnetosphere by 3-D evolution of the Kelvin-Helmholtz instability

Yosuke Matsumoto^{1,2} and Kanako Seki²

¹ Graduate School of Environmental Studies, Nagoya University, Nagoya, Aichi, JAPAN,

² Solar-Terrestrial Environment Laboratory, Nagoya University, Nagoya, Aichi, JAPAN

[ymatumot@stelab.nagoya-u.ac.jp](mailto:yumatumot@stelab.nagoya-u.ac.jp)

An appearance of cold and dense plasma at the geosynchronous orbit is one of the characteristic natures after a prolonged northward IMF duration. This cold dense material can contribute to the enhancement of the ring current density, which results a further declination of Dst. Therefore investigating the origin, path and fate of the cold dense plasma is important to understand how it preconditions the magnetosphere during a quiet interval before storm [Borovsky and Steinberg, 2006]. Observational evidences have shown that the cold dense material builds up during the northward IMF intervals in the flanks of the magnetosphere [e.g., Wing and Newell, 2002] which is referred to as the low latitude boundary layer (LLBL). The entry process of the solar wind plasma into the magnetosphere during the northward IMF conditions has been controversial in contrast to the Dungey's reconnection model for the southward IMF cases. The major candidate processes are the double lobe reconnection model [Song *et al.*, 1999], in which newly closed magnetic field lines on the dayside magnetopause capture the solar wind plasma, and the turbulent transport by the Kelvin-Helmholtz instability (KHI) driven by the fast solar wind flow.

We have studied the solar wind entry process by the KHI. Matsumoto and Hoshino [2004, 2006] showed by 2-D MHD and full particle simulation studies that the strong flow turbulence is a natural consequence of the nonlinear development of the KHI through the secondary Rayleigh-Taylor instability, if there is a large density difference between the two media. The mechanism is fundamentally two-dimensional and therefore we term it the 2-D secondary instability. They also showed that the turbulent development greatly contributes to the solar wind plasma transport deep into the magnetosphere. Based on the previous 2-D studies, the 3-D nonlinear evolution of the KHI is studied by performing MHD simulation. Starting with a uniform background field configuration and a velocity shear layer, we obtained a unique feature which arose due to the three-dimensionality: the KH vortex is susceptible to the 3-D secondary instability which converts the rotating energy into the magnetic energy by generating large amplitude Alfvénic fluctuations. Once the 3-D secondary instability is excited, the mode cascade starts after the amplitude of the fluctuation reaches to a certain level compared to the background field. In this presentation, we show that the nonlinear evolution of the KHI by introducing the 2-D and 3-D secondary instabilities can contribute to the effective mass transport of the solar wind plasma into the magnetosphere during the prolonged northward IMF intervals.

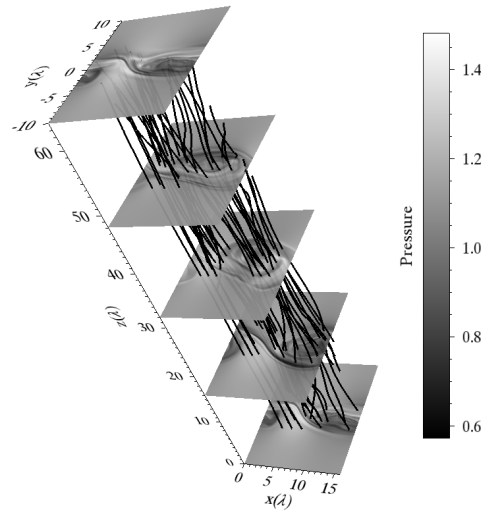

Figure 1: 3-D evolution of the Kelvin-Helmholtz instability. Magnetic field lines are represented by solid strings. Cross-sectional profiles of the plasma pressure are also added in the three-dimensional view.

Effect of Shock Angle on Fast and Direct Acceleration of Electrons in High Mach Number Quasi-Perpendicular Shocks

T. Amano¹ and M.Hoshino¹

¹ *Department of Earth and Planetary Science, University of Tokyo, Bunkyo-ku, Tokyo, JAPAN*
amano@eps.s.u-tokyo.ac.jp

Sudden increase in energetic particle flux associated with the passage of interplanetary shocks (IPs) driven by Coronal Mass Ejections (CMEs) is of particular importance in the context of predictive space weather. However, the physics of particle acceleration, in particular electrons, in collisionless shocks is poorly understood so far.

Hence we have studied the electron dynamics in high Mach number quasi-perpendicular collisionless shock waves by utilizing a one dimensional electromagnetic particle-in-cell code. Previous studies of high Mach number shocks (e.g. Shimada & Hoshino 2000; Hoshino & Shimada 2002; Schmitz, Chapman & Dendy 2001) have demonstrated that energetic electrons are generated on a fairly fast time scale within the transition region through interactions with waves excited by strong plasma instabilities. Hoshino & Shimada (2002) showed that the efficient energization of electrons occurred while they were trapped in large amplitude, electrostatic solitary waves (ESWs) produced in the nonlinear development of Buneman instability. They argued that the energization was the result of electron surfing acceleration (ESA), which had been studied by many authors (e.g. Sagdeev 1966; Katsouleas & Dawson 1983). However, their studies were restricted to strictly perpendicular shocks and oblique shock waves were not taken into account. Our numerical simulations of quasi-perpendicular shocks ($\theta_{Bn} = 80$) have shown that energetic electrons are generated through ESA as well as purely perpendicular shocks. In addition to this, we have found that energetic electrons escaping to the upstream direction with higher energies than those observed in purely perpendicular shocks. Besides, their energies are also higher than those found in the downstream. Consequently, their higher energies cannot be explained by the leakage from the downstream. Thus, we can conclude that the energetic electrons are accelerated in the transition region and preferentially reflected back to the upstream. The observed energetic electrons orbits indicate that at first, they are accelerated perpendicular to the magnetic field at the leading edge of the transition region by ESA. Thus, their pitch angles increase. As a result, they are easily reflected by the mirror force around the magnetic overshoot where the compression ratio becomes maximum. The resulting particle energies are several times higher than those produced by ESA.

The latter acceleration process accompanied by the reflection is known as shock drift acceleration (SDA) and have been extensively studied (e.g. Wu 1984; Leroy & Mangeney 1984). SDA can be understood as the mirror reflection process in the de Hoffman Teller frame where the motional electric field vanishes. Therefore, the theory of SDA predicts that as the shock angle approaches to 90 degree, the acceleration efficiency (or the maximum energy) increases, whereas the number of accelerated particles decreases. In contrast to this prediction, our simulation results depict that the preacceleration perpendicular to the ambient magnetic field due to ESA increases the number of reflected electrons, hence the maximum energy. Because of this, electron acceleration efficiency in high Mach number quasi-perpendicular shocks will be higher than expected from the theories of SDA or ESA.

The test of the Fermi acceleration of the plasmoids passing through the fast shock

N. Nishizuka¹ K. Nishida² and K. Shibata²

¹ Department of Astronomy, Kyoto University, JAPAN,

² Kwasan and Hida observatories, Kyoto University, JAPAN

nisizuka@kwasan.kyoto-u.ac.jp

For these twenty years, Yohkoh satellite and RHESSI satellite revealed that nonthermal ions (100MeV-1GeV) and electrons (20-100keV) are generated in the solar flares and that their energy distribution is well fitted to the power law spectrum. In order to interpret the observations of Hard X-rays, gamma-rays and radio wavelength, many mechanisms of the particle accelerations to form the power law energy spectrum have been considered. But it is very difficult to interpret the particle acceleration because of its complexity. In spite of many efforts, the particle acceleration of solar flares has not been well understood, even where the particles are accelerated and how they are.

Typical impulsive flares sometimes have three Hard X-ray emission sources; two of them are footpoint sources of the magnetic loops and the other is located above the loop top. Footpoint Hard X-ray sources are interpreted as a bremsstrahlung emission by the high-energy particles precipitating themselves into the chromospheres in the thick-target model. But the mechanism of the loop top Hard X-ray emissions has not been fully understood. The time-of-flight measurements (Aschwanden et al. 1996) provided observational constraints on the topology of the acceleration region, but is still obscure whether the loop top source is included in the acceleration region or not.

The magnetohydrodynamic (MHD) simulation of the magnetic reconnection showed the fast mode shock under the X point, reconnection point. And it was also shown that the tearing instability occurred in the current sheet generates some magnetic islands. In some cases, particles trapped inside the islands, namely plasmoids, precipitate down to the fast shock with Alfvén velocity.

In this presentation we introduce our idea of the particle acceleration using the fast shock and the circular magnetic field of the plasmoid. Figure 1 shows the simplest scenario.: (a)The particles are trapped inside the plasmoid generated by the magnetic reconnection and propagate down to the fast shock. (b)They are reflected at the shock front by magnetic mirror effect due to magnetic pressure. (c)As the plasmoid pass through the shock front, the distance between the reflection points becomes shorter and shorter, and they are accelerated by the 2nd-order Fermi acceleration to the relativistic energy range. (d)At last when the length scale becomes comparable to their Larmor radius, they escape from the magnetic trap.

Further more we analyzed the energy spectrum of the accelerated particles. At first we calculated the energy spectrum analytically assuming the ideal particle orbit along the circular magnetic field. Figure 2 is the energy spectrums of the particles before acceleration and after acceleration in this analytical way. Secondly we tried the test particle simulation in some given electromagnetic fields, one is determined analytically and the other is solved by the MHD reconnection simulation. We used the convective electric field ($E_{conv} = -u \times B/c$). In the inhomogeneous vicinity of magnetic O-lines, the guiding center drift of the particles due to the gradient B drift or the curvature drift points into the direction of the convective electric field, which, therefore, contributes to the particle acceleration. Every time particles are reflected at the shock front, although sometimes their pitch angles are too small for them to be reflected, they are accelerated in this way in stead of the 2nd-order Fermi acceleration. Finally we show Hard X-ray spectrum calculated from the particle energy distribution.

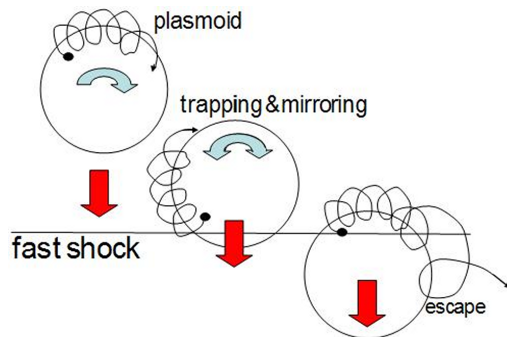

Figure 1: The scenario of the Fermi acceleration of the plasmoid passing through the fast shock

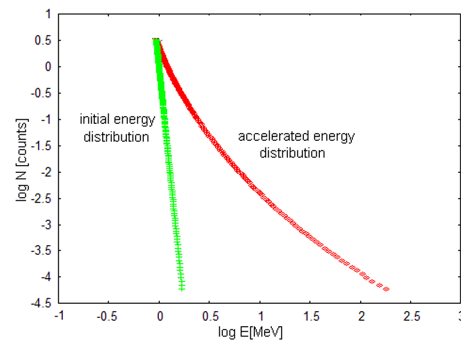

Figure 2: energy spectrum calculated by analytical method

Dynamics of the ring current during severe magnetic storms

Y. Ebihara¹ and M.-C. Fok²

¹ *National Institute of Polar Research, Tokyo, JAPAN*

² *NASA GSFC, Greenbelt MD, USA*

ebihara@nipr.ac.jp

We show how the ring current is profoundly influenced by the ionospheric conductivity which is controlled by solar radiation and auroral electron precipitation. As a result of the accumulation of charged particles in the inner magnetosphere, an electric current flows perpendicularly to magnetic field lines (so-called the ring current). Field-aligned currents (FACs) flow when the divergence of the perpendicular electric current is nonzero. To remove the space charge deposited by the FACs, Pedersen currents are established in the ionosphere. The additional electric field distorts the convection electric field that is the prime driver for the ring current development. After performing a ring current simulation that self-consistently solves the kinetic equation of ring current protons and the closure of the electric current between the magnetosphere and ionosphere, we obtained the following results. (1) The conductivity for $F_{10.7} = 250 \times 10^4$ Jy (solar maximum condition) is found to result in a ring current that is about 29% stronger than for $F_{10.7} = 70 \times 10^4$ Jy (solar minimum condition). (2) The conductivity at equinox results in a ring current that is about 5% stronger than at solstice because the two-hemisphere height-integrated conductivities at equinox are higher than at solstice. This would be a new mechanism for explaining the semiannual variation of Dst. (3) The conductivity at 12 UT results in a ring current that is about 7-8 % stronger than at 00 UT. (4) Simulation with a realistic auroral conductivity estimated from the IMAGE/FUV auroral imager data reveals the fact that the overshielding condition is produced when the auroral conductivity decreases abruptly near the Dst minimum, triggering a rapid decay of the ring current. (5) The strength of the ring current is no longer proportional to the plasma sheet density because of an increase in the degree of the shielding with the plasma sheet density. The total energy of the ring current is found to be proportional to square root of the plasma sheet density.

Storm-time equivalent currents derived from a meridional magnetometer chain and the investigation of associated dynamics

R.Kombiyil¹, H.Fukunishi¹, S.Watanabe², K.Shiokawa³ and K.Yumoto⁴

¹ *Planetary Atmosphere Lab, Department of Geophysics, Tohoku University, Sendai, Japan*

² *Department of Earth and Planetary Sciences, Graduate School of Science, Hokkaido University, Hokkaido, Japan*

³ *STELAB, Nagoya University, Nagoya, Japan*

⁴ *Space Environmental Research Center, Kyushu University, Japan*

rkombiyil@gmail.com

There is a need for modeling the ionospheric sheet currents locally, over a certain region using ground based and/or satellite observations to help us better understand the physics of changes happening during geomagnetic storms. Our interest is to investigate such storm-time changes in the low-latitude ionosphere, by taking into account the coupling between high- and low-latitudes. We use magnetic data from the 210 degree meridian chain and calculate the ionospheric (~ 120 km) sheet currents for geomagnetic storms of varying intensities, spanning different seasons and solar cycle. Many factors contribute differently to the observed H component variations along the chain and one needs to address them using case based arguments, since quantifying them is a difficult task. We separate the observed horizontal field (H) into the external and internal parts and continue the external component towards the source to arrive at the ionospheric equivalent currents. The algorithm can be applied to any meridional chain of magnetometers accounting for the interpretation of conductivity (magnetotellurics) and wavelength in the spatial domain. It is also planned to discuss the storm-time dynamics and associated changes in the low-latitude ionosphere using the derived electrodynamic parameters (conductivities, electric fields) which will be used together with an existing numerical model of the ionosphere.

Numerical modeling of the circulation of ionospheric and solar wind particles in the magnetosphere

N. Terada^{1,2} and T. Tanaka^{2,3}

¹ *National Institute of Information and Communications Technology, Koganei, Tokyo, JAPAN,*

² *CREST, Japan Science and Technology Agency, Saitama, JAPAN,*

³ *Department of Earth and Planetary Science, Kyushu University, Fukuoka, JAPAN*

teradan@nict.go.jp

Recent satellite observations have revealed that the ionosphere is an important source of the magnetospheric plasma. O^+ ions of ionospheric origin have been shown to dominate the ring current region during intense magnetic storms, while other ionospheric ions such as N^+ contribute to the ring current with the ratio as high as $N^+/O^+ \sim 0.5$. Despite the importance of their contributions to the ring current hence to the development of geomagnetic storms, global magnetosphere models have not included them in a self-consistent manner. This is simply because they are quite computer intensive due to the presence of strong magnetic field in the ring current region, and require elaborate techniques to accommodate the kinetic effects, anisotropy effects, diverse temporal scales, etc in a global model. We have recently developed a particle tracing model in which ions originating from the topside ionosphere and the solar wind are followed in the magnetosphere obtained by a global TVD MHD model. We will present results of the numerical modeling and compare them with satellite observations with a particular emphasis placed on the formation of the ring current during a geomagnetic storm.

Super-Droplet Method: a Particle-Based Cloud Microphysics Coupled with Nonhydrostatic Model

S. Shima, S. Kawahara, F. Araki, T. Sugiyama, A. Kawano, S. Hirose, and K. Kusano

Earth Simulator Center, JAMSTEC, Yokohama, Kanagawa, JAPAN,

s_shima@jamstec.go.jp

Although clouds play a crucial role in atmospheric phenomena, the numerical modeling of cloud is not well established so far. Especially, it is still difficult to perform the accurate simulation of cloud microphysics, though several simulation methods, such as bulk parameterization method, spectral (bin) method, and the exact Monte Carlo method, have been proposed.

We develop a novel simulation model of cloud microphysics, named Super-Droplet Method (SDM), which enables accurate calculation for the condensation/evaporation, the stochastic coalescence, and the motions of all the droplets with reasonable cost in computation. The methodology to calculate the coupling between the super-droplets and the non-hydrostatic cloud dynamics is also developed. We confirm that the result of our Monte Carlo scheme for the coalescence of super-droplets agrees very well with the exact solution of stochastic coalescence equation. The practicality of SDM is also demonstrated by the regional simulations of a shallow maritime cumulus.

We have developed SDM only for warm rains with one soluble substance as the CCN, but it is not difficult to extend SDM to incorporate many properties of clouds, such as, several types of ice crystals, several types of soluble/insoluble CCN, their chemical reactions, electrification, and the breakup of droplets. Further, it is estimated that the computational cost will be very low compared to the cost of spectral (bin) method when the number of attributes of super-droplets, such as the radius of droplet and the masses of each type of CCN, is increased larger than $2 \sim 4$.

As a conclusion, though several extensions and validations are still necessary, we expect that SDM will lead us to a deep understanding of aerosol, clouds and precipitation interactions, and could be useful for weather forecast, the optimization of artificial rain, and the accurate prediction of global warming.

Macro-micro Interlocked Simulation of Gas Detonation

A. Kawano¹ and K. Kusano¹

¹ *Earth Simulator Center, JAMSTEC, Yokohama, Kanagawa, JAPAN.*

kawanoa@jamstec.go.jp

Macro-Micro Interlocked (MMI) simulation, in which the interaction between microscopic and macroscopic scales is calculated by connection between a microscopic and a macroscopic models, is an advanced methodology for the multi-scale simulation. We have developed a basic algorithms of MMI simulation for gas-phase detonation using an interlocking technique between the direct simulation Monte-Carlo (DSMC) method and the HLLC method.